

DEC.  
16



15c.  
Per Copy

# RADIO

REG. U.S. PAT. OFF.

# WORLD

The First and Only National Radio Weekly

1933

612th Consecutive Issue—Twelfth Year

## A Compact D-C Volt-Current-Ohmmeter

Coil-Switching  
in a Regenerative  
Short-Wave Set

### AERIALS

### Glow-Discharge Oscillator

# SWITCH TYPE CONVERTER

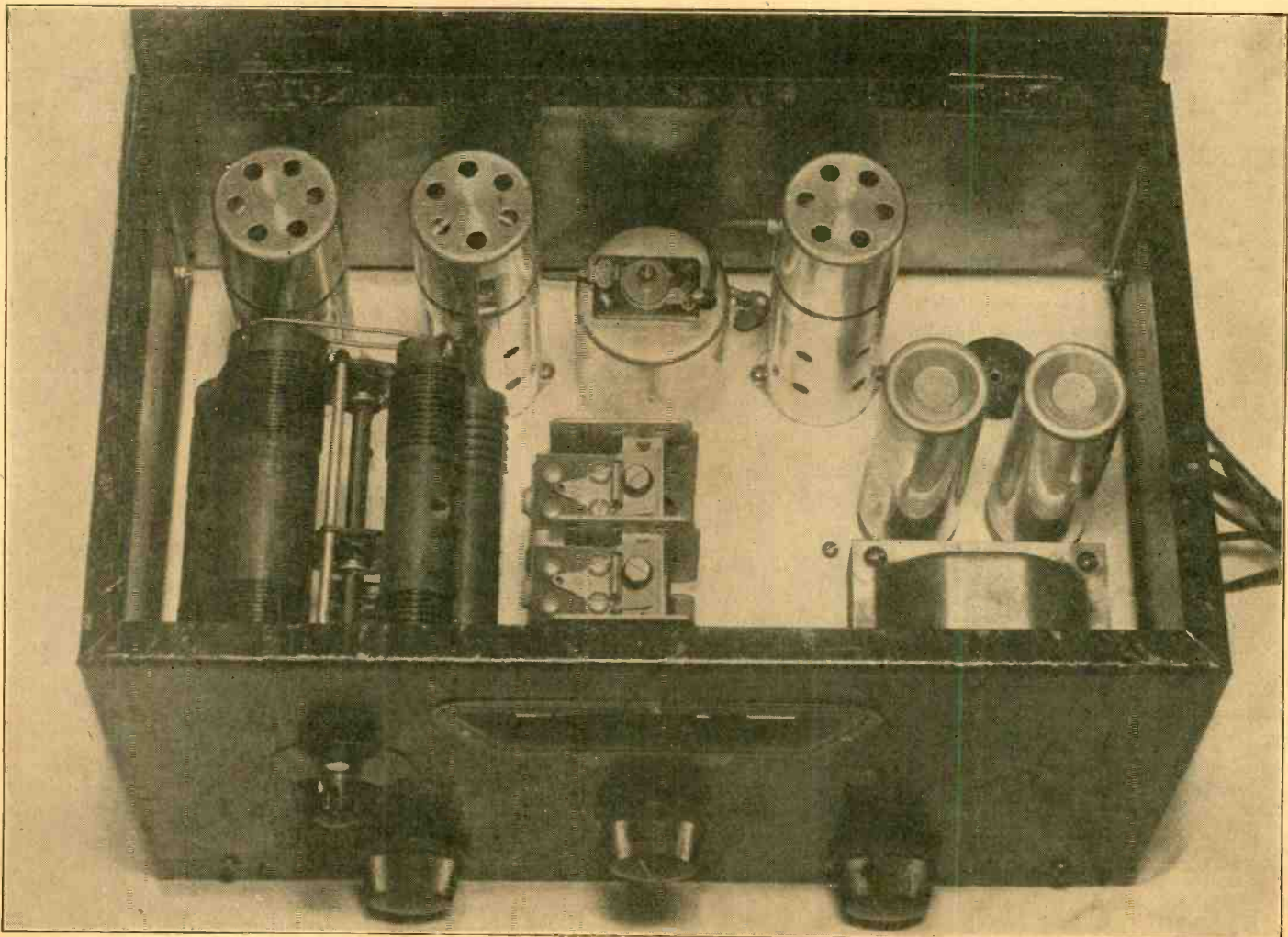

A switch type short-wave converter, with self-contained rectifier and B filter. See page 9.



## THE "ADAM'S" 4

SHORT-WAVE CONVERTER, 10 to 200 Meters  
Described in This Issue of RADIO WORLD by Herman Cosman

THE beginner in the field of short waves will without doubt find a great deal of interest in this new converter unit which is connected to the regular broadcast receiver; utilizing the high amplification and fine quality of the latter. While many other converter units have been designed before, tests have proven that this one produced such remarkable results.

On the first trial the following stations were heard on the loud speaker:  
VE9JR—25.6 meters, Winnipeg, Manitoba.  
FYA—25.8 meters, Pontoise, France.

The unit supplies its own power, so a power transformer and a type '80 tube are included for this purpose.

The unusual points in the design of the "Adam's" are the use of an intermediate frequency amplifier in the converter unit—and use of a tuned-plate oscillator. The first assures plenty of amplification, as well as adding a tuned circuit to the complete receiver-converter arrangement. The second provides a stable oscillator system which is essential in a successful short-wave superheterodyne.

Complete Kit of Parts less tubes..... **\$17.95**  
Wired and Tested, less tubes..... **\$5.00 Extra**

### POWERTONE Universal A.C.-D.C. Short-Wave Receiver



On the first trial, it received Melbourne, Australia—over 11,000 miles from New York City. Universal sets are rapidly gaining popularity due to its extreme simplicity in design, and its universality.

Uses 1-43, 1-78 and the new 1-25Z5 tube. Hammarlund parts add to its fine performance. Tunes from 15 to 200 meters.

Kit of parts, 4 coils, cabinet and instructions..... **\$8.95**  
Wired and Tested—\$2.00 extra

### The BAIRD UNIVERSAL A.C.-D.C. SHORT- WAVE CONVERTER

Described in RADIO WORLD, Nov. 4, 1933

A Powertone Laboratory product that will operate efficiently with any radio set on the market today.

Covers the short-wave band from 15 to 200 meters. Tests in the laboratory assure reception of police calls, airplane reports and amateur broadcasts, as well as foreign stations, with incredible clarity.

The converter is housed in an attractive walnut cabinet. Complete kit of parts, instructions, 4 coils, less tubes..... **\$4.95**  
Kit of tubes... \$1.25 Cabinet... \$1.00  
Wired and tested..... **\$1.50 extra.**

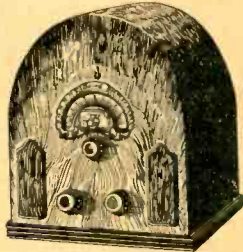

Now Ready!

Handy  
Servicemen's  
Manual

Regularly, \$1.00

Full of important information for the serviceman and set builder. Short-wave converter, amplifier hookups, etc.—charts—service hints—tube characteristics—and many others too numerous to mention.

**25c**

TRY-MO RADIO CO., INC.  
Dept. RW, 85 Cortlandt St., New York  
Branch: 179 Greenwich Street

## LEOTONE Short-Wave A-C Set or Kit 17 to 200 Meters

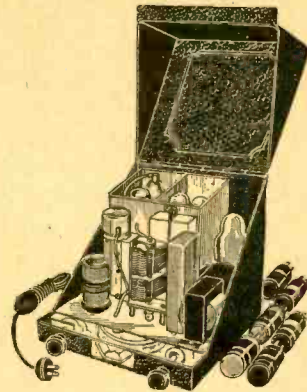

THIS newly-designed receiver has obtained marvelous results. It is THE receiver for short-wave fans and EXPERIMENTERS who desire world-wide reception, Police reports, and the thrill of distance.

The Leotone A-C receiver uses the following ARCTURUS tubes: 58 r-f, 57 detector, 56 first audio, 2A5 output, and 80 rectifier.

Complete Kit, including Foundation unit, cabinet, all parts, speaker, with matched set of Arcturus tubes and eight Gen-Win plug-in coils... **\$18.95**  
Completely wired, including tubes, speaker, everything..... **\$21.95**

Foundation Kit, including metal case, chassis and shielded compartment, **\$2.45**

LEOTONE RADIO CO.  
63-W Dey St. New York, N. Y.

NEW RADIO AMATEUR'S HANDBOOK, 180,000 words, 207 illustrations, 218 pages (10th edition issued 1933). Issued by the American Radio Relay League. Price, \$1.00 per copy. Radio World 145 West 45th Street, New York, N. Y.

## ACME TRANSFORMERS

Power  
Audio  
Step  
Down

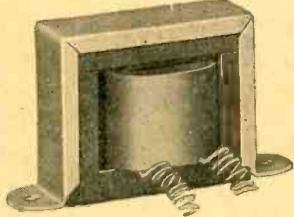

Write for Bulletin 126 describing Power and Audio Transformers. Bulletin 121-A describes Step-Down Transformers.

THE ACME ELECTRIC & MFG. CO.  
1445 Hamilton Avenue Cleveland, Ohio

## An Extraordinary Bargain!

Three-Gang Condenser FREE with 13-week Subscription @ only \$1.50

THE highest grade commercial gang condenser made, die-cast frame, brass plates, 3/4" diameter shaft extending at both ends. Condenser can be used therefore with either direction of dial rotation. Rigidity is of highest degree. Rotors can be shifted on shaft and locked tight for peaking at high-frequency end of band, thus dispensing with trimmers. Capacity, 0.0004 mfd. Full band coverage 1,500 to 540 kc (and more) with coils intended for 0.00035 to 0.00041 mfd. Premium sent express collect (shipping weight 5 lbs.) on receipt of \$1.50 for 13 weeks subscription for Radio WORLD (13 issues).

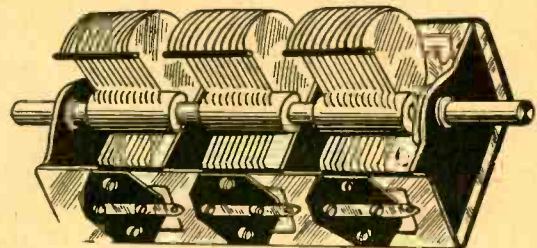

The condenser measures 4 x 6 1/2 inches, overall frame size; shafts extend 1 inch beyond frame.

RADIO WORLD, 145 West 45th Street, New York, N. Y.

"SERVICING SUPERHETERODYNES," by John F. Rider. A reliable aid to the service man or to organizations in tackling superhet service problems. 161 pages, canvas cover. Price \$1.00. Radio World 145 W. 45th St., New York, N. Y.

"A B C OF TELEVISION" by Yates—A comprehensive book on the subject that is attracting attention of radioists and scientists all over the world. \$3.00, postpaid. Radio World, 145 West 45th St., N. Y. City.

## RCA INSTITUTES

Recognized Standard in Radio Instruction Since 1909  
Technical Training Courses in Radio and Associated Electronic Arts  
RESIDENT SCHOOLS NEW YORK AND CHICAGO  
Illustrated Catalog on Request  
EXTENSION COURSES FOR HOME STUDY under convenient "no obligation" plan.  
RCA INSTITUTES, INC.  
Dept. WR-1  
75 VARICK STREET, NEW YORK  
1154 MERCHANDISE MART, CHICAGO

## Powertone Wallace Short Wave Receiver

The battery operated short-wave set which won the Hoover Cup for premier short-wave design and performance; well designed both electrically and mechanically. Built of the finest precision parts, each operating at maximum efficiency at all times; the Wallace has many features to recommend it to all interested in short-wave reception. Among these features are:

1. Band spread tuning for the crowded bands, controlled by a single panel switch.
2. Ultra Low-Loss coils wound with silver ribbon.
3. Each circuit individually controlled.
4. Highly efficient tuned antenna system.
5. Zero body capacity.
6. 15-200 meter tuning range.

The set is for earphone operation, using two 230 tubes, which require a 2-volt filament supply and 45-90 volts of "B" battery.

The receiver uses four plug-in coils whose tuning ranges are:  
No. 1. coil—20-32 meters  
No. 2. coil—40-60 meters  
No. 3. coil—75-150 meters  
No. 4. coil—150-200 meters

Complete kit of parts, with one coil..... **\$14.70**  
Each additional coil..... **1.70**  
Wiring and testing (if desired) extra..... **3.25**

Guaranty Radio Goods Co., 145 W. 45th St., New York, N. Y.

I saved 1/2 by buying direct from the Midwest Laboratories

Yes, and it gives you WORLD-WIDE Reception!

*Amazing New*  
**SUPER Deluxe**

**16-TUBE**  
**ALL-WAVE Radio**

9 TO 2,000 METERS

**30 DAYS FREE TRIAL**

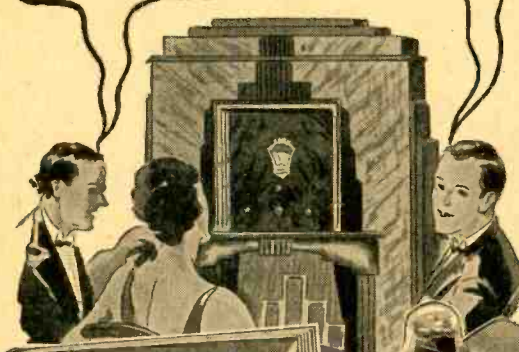

**WRITE FOR NEW FREE CATALOG**



**B**EFORE you buy any radio, write for this big new FREE Midwest catalog... printed in four colors. It has helped thousands of satisfied customers save from 1/3 to 1/2 on their radios... by buying direct from the Midwest Laboratories. You, too, can make a positive saving of 30% to 50% by buying a Midwest 16-tube de luxe ALL-WAVE radio at sensationally low direct-from-laboratory prices. You'll be amazed and delighted with its super performance! Broadcasts from stations 10,000 miles and more away are brought in... "clear as locals". You get complete wave length coverage of 9 to 2,000 meters (33 megacycles to 150 KC). Now, you can enjoy the new DX-ing hobby... and secure verifications from world's most distant stations.

These bigger, better, more powerful, clearer-toned, super-selective radios have FIVE distinct wave bands: ultra-short, short, medium, broadcast and long... putting the whole world of radio at your finger tips. Now listen in on all U. S. programs... Canadian, police, amateur, commercial, airplane and ship broadcasts... and programs from the four corners of the earth. Thrill to the chimes of Big Ben from GSB, at Daventry, England—tune in on the "Marseillaise" from FYA, Pointoise, France—hear sparkling music from EAQ, Madrid, Spain—listen to the call of the Kookaburra bird from VK2ME, Sydney, Australia—etc. Never before so much radio for so little money! Write for FREE catalog.

**WORLD'S GREATEST RADIO VALUE**  
**\$49.50**  
*with New*  
**Deluxe Auditorium Type SPEAKER**

**... 40 NEW 1934 FEATURES ...**

Try this Midwest radio... in your own home... for thirty days before you decide. See for yourself the 40 new 1934 features that insure amazing performance. Other features include: Automatic Select-O-Band, Amplified Automatic Volume Control, 16 New Type Tubes, Balanced Unit Superheterodyne Circuit, Velvety Action Tuning, Super-Power Class "A" Amplifier, 29 Tuned Circuits, New Duplex-Diode-High Mu Pentode Tubes, No-Image Heterodynes, Full Rubber Floated Chassis, Variable Tone Blender, Centralized Tuning, 7 KC Selectivity, New Thermionic Rectifier, Automatic Tone Compensation, Auditorium Type Speaker, etc. These features are usually found only in sets selling from \$100 to \$150.

**AMAZING FOREIGN RECEPTION**

AKRON, OHIO—My Midwest-16 is a real getter for distance. Received 205 stations on regular wave band... including U. S., Canadian, Mexican, Cuban and Hawaiian stations. Also many police, airport and "ham" stations from all over the country. Have logged England, France, Germany, Madrid, Rome, on 15-30 meter band. South American stations include Venezuela, Colombia, Brazil, Yucatan.—L.H. MOELLER, 793 N. South St.

**DEAL DIRECT WITH LABORATORIES**  
Increasing costs are sure to result in higher radio prices soon. Buy before the big advance... NOW, while you can take advantage of Midwest's amazingly low prices. No middlemen's profits to pay! You save from 30% to 50% when you buy direct from Midwest Laboratories... you get 30 days FREE trial—as little as \$5.00 down puts a Midwest radio in your home. Satisfaction guaranteed or your money back! FREE catalog shows sensational radio values. Write TODAY!

**SAVE UP TO 50%**

**TERMS AS LOW AS \$5 DOWN**

**NEW STYLE CONSOLES**  
Write quickly for your FREE copy of the new Midwest catalog. It pictures a complete line of beautiful, artistic deluxe consoles and chassis... in four colors! Sensational low prices save you 30% to 50%. Also shows performance curves that prove Midwest radios out-perform most of the \$150 sets. You can order your Midwest radio from this catalog with as much certainty of satisfaction as if you were to select it personally at our great radio laboratories. Write TODAY!

**MAIL COUPON TODAY! FOR AMAZING 30-DAY FREE TRIAL OFFER AND NEW 1934 CATALOG**

MIDWEST RADIO CORP., Dept. 442, Cincinnati, Ohio.

Without obligation on my part send me your new FREE 1934 catalog, and complete details of your liberal 30-day FREE trial offer. This is NOT an order.

AGENTS! Make Easy Extra Money  
Check Here for Details

Name.....  
Address.....  
City..... State.....

**MIDWEST RADIO CORP.**  
DEPT. 442 — CINCINNATI, OHIO, U. S. A.  
Established 1920 Cable Address Miracc ABC 5th Edition

ROLAND BURKE HENNESSY  
Editor

HERMAN BERNARD  
Managing Editor

# RADIO WORLD

REG. U.S. PAT. OFF.

The First and Only National Radio Weekly  
TWELFTH YEAR

J. E. ANDERSON  
Technical Editor

J. MURRAY BARRON  
Advertising Manager

Vol. XXIV

DECEMBER 16th, 1933

No. 14. Whole No. 612

Published Weekly by Hennessy Radio Publications Corporation, 145 West 45th Street, New York, N. Y.

Editorial and Executive Offices: 145 West 45th Street, New York

Telephone: BR-yant 9-0558

OFFICERS: Roland Burke Hennessy, President and Treasurer; M. B. Hennessy, Vice-President; Herman Bernard, Secretary.

Entered as second-class matter March, 1922, at the Post Office at New York, N. Y., under Act of March 3, 1879. Title registered in U. S. Patent Office. Printed in the United States of America. We do not assume any responsibility for unsolicited manuscripts, photographs, drawings, etc., although we are careful with them.

Price, 15c per Copy; \$6.00 per Year by mail. \$1.00 extra per year in Foreign countries. Subscribers' change of address becomes effective two weeks after receipt of notice.

## A Volt-Current-Ohmmeter in a Steel Box 5x5x3 Inches

By Herman Bernard

**I**N a commercially-obtainable finished steel cabinet only 5x5x3 inches it is possible to build a d-c meter for measuring voltages, currents and resistances.

Assuming the preferred 0-1 milliammeter, the voltmeter rating would be 1,000 ohms per volt. The ranges can be selected as desired. For conformity with the current scale the selections in the present instance have been 0-1,000 volts, 0-100 volts and 0-10 volts, while an odd range, 0-3 volts, was selected merely because the series resistor for the ohmmeter circuit could thus be put to double use. The actual voltages for this scale would be determined by mental arithmetic, the maximum of the scale being assumed as 10 and the actual voltage being 0.33 of the apparent reading.

The currents readable, consistent with the scale, are 0-100, 0-10 and 0-1 milliamperes, and besides there is a shunt for 0-500 milliamperes (half an ampere), so that large sets can be measured for their total B drain, and also filament or heater current of d-c tubes measured. The apparent reading, after multiplication by 1,000, is divided by 2 mentally, to give the actual current.

### Resistance, 1 Ohm to 100,000 Ohms

The ohmmeter feature is in two parts. One is standard, with a 3-volt dry battery of the vest-pocket size, obtainable in chain stores and elsewhere, requiring a 3,000-ohm series resistor for measurements of from below 100 to above 100,000 ohms. This is for determining unknown high resistances, Rxh. For determining unknown low resistances, Rxl, the meter itself is shunted, when the terminals for the Rxh are shorted. Thus the meter extends to full-scale deflection on this shorting, and any unknown resistance across the meter, from less than 1 ohm to a bit more than 1,000 ohms, may be determined by the relationship to the known meter resistance. The manufacturer of the meter will inform you of its resistance. The Weston 301 meter, 0-1 milliammeter, has a resistance of 27 ohms. Meters of other resistance than this would require a different shunt for 0-10 milliamperes and also would yield a different calibration for Rxl.

The connections are made to tip jacks.

A pair of flexible leads would be used, preferably with the usual tip plugs at one end and small rubber-insulated spring clips at the other end.

### The Switch

Besides the meter, the box, the multipliers, the tip jacks, and the small battery, a switch is used for introducing the shunts. This switch may be of the single-pole, four-throw type, so that there will be three throws for 0-500, 0-100 and 0-10 milliamperes, and an off position. A hole on one side of the box accommodates the switch.

No shelf is needed for mounting the various resistors, because due to the compactness, these parts may be soldered to a common meter lead and to the respective jack lugs. Even the battery is made self-supporting, in a sense, by connecting to one of these lugs and using a wire from meter to the "raw" meter output post as a strap.

The layout may be prepared along the general lines shown. If the top left, looking at the top of the box, is plus for 0-1,000 volts, the next lower point is meter minus, and the next lower or third jack at left is plus 0-100 volts. Thus there is a common minus, and either range is used by shifting one lead. For the next three posts there is again a common minus, the higher voltage range, 0-10 volts, farther up, the lower voltage range, 0-3 volts, farther down.

On the right-hand side the same relative positions of plus and minus posts are followed, currents being read here, except for the lower pair, where the high resistances are read (Rxh). As stated, the same posts used for 0-1 milliammeter, which are the "raw" meter terminals, are used for low resistance measurements when the high-resistance measurement posts are shorted.

### Resistance Curves

As the current scale of the meter has no linear relationship to resistance values of either type, it will be necessary to plot a curve, and for each resistance range, and consult the curve after the current reading is determined. That is the next best thing to a resistance-calibrated meter, although of course computation may be resorted to at will.

For the high resistances the unknown resistances may be computed by Ohm's law as follows:

$$R_x = \frac{3}{I} - 3,000$$

where Rx is the unknown resistance, 3 is the voltage of the battery, and I is the current reading as determined by the meter, expressed in decimal fractional ampere, and 3,000 is the series resistor which must be deducted because otherwise included in the result.

Sufficient data for drawing a curve may be obtained from the following values:

I	R <sub>xh</sub>	I	R <sub>xh</sub>
0.000025	117,000	0.0006	3,000
0.00005	57,000	0.0008	750
0.0001	27,000	0.00085	530
0.00015	17,000	0.0009	333
0.0002	12,000	0.00095	158
0.0004	4,500	0.000975	77

### The Low-Resistance Table

The values given above are on the basis of a meter that has 20 divisions, or 50 microamperes per division, a value being given for each 100 microamperes, except that for 850, 950 and 975 microamperes, the last-named being judged visually as the halfway distance of the final bar. The full-scale deflection, of course, is zero resistance, the half-bar visual point being 77 ohms, and the same half-bar method is used at the high-resistance end. However, for general purposes the low-resistance limit for Rxh is accepted as 100 ohms.

For the low-resistance measurement, Rxl, if the unknown is the same as the meter resistance, 27 ohms, the reading is half of full-scale or, 500 microamperes. The following table gives sufficient data to run a curve:

I	R <sub>xl</sub>	I	R <sub>xl</sub>
0.000025	0.685	0.0006	40.1
0.00005	1.408	0.0008	107.0
0.0001	2.97	0.00085	151.6
0.00015	4.72	0.0009	240.5
0.0002	6.68	0.00095	508.0
0.0004	17.8	0.000975	1,042.0

As stated previously, if the meter resistance is not 27 ohms the above values will not hold.

**LIST OF PARTS**

- One 0-1 milliammeter (meter resistance of 27 ohms assumed).
  - Wire-wound series multiplier resistors for voltages: one of 1,000,000 ohms; one of 100,000 ohms; one of 10,000 ohms; one of 3,000 ohms\*.
  - Wire-wound shunt resistors for currents; one of 0.054 ohms, one of 0.273 ohm; one of 3 ohm.
  - One 3-volt tiny battery, consisting of two 1.5-volt dry cells in one container.
  - One single-pole four-throw switch, insulated shaft type.
  - Eight red tip jacks (positive).
  - Four black tip jacks (positive).
  - Two tip jacks, to be painted some other color than black or red, to distinguish them for high resistance measurements.
  - One wrinkle-finished black cabinet, steel construction, 5 x 5 x 3 inches. Hole for mounting switch. Four rubber feet, to be cemented at bottom corners of the box.
  - One insulating panel, drilled for meter and posts.
  - Two sheets of plotting paper, small enough so both can be cemented to the base of the box, inside the feet.
  - One pair of test leads, tip plugs at one end; rubber-insulated spring clips at other end.
- \*The meter resistance is immaterial for the higher resistance multipliers, but if 1/2 per cent accuracy is required of the low resistor, order 2,973 ohms instead of 3,000 ohms, as 2,973 ohms, with the meter resistance, equals 3,000 ohms.
- If panel is to be engraved, this must be done on the drilled panel before any parts are mounted.

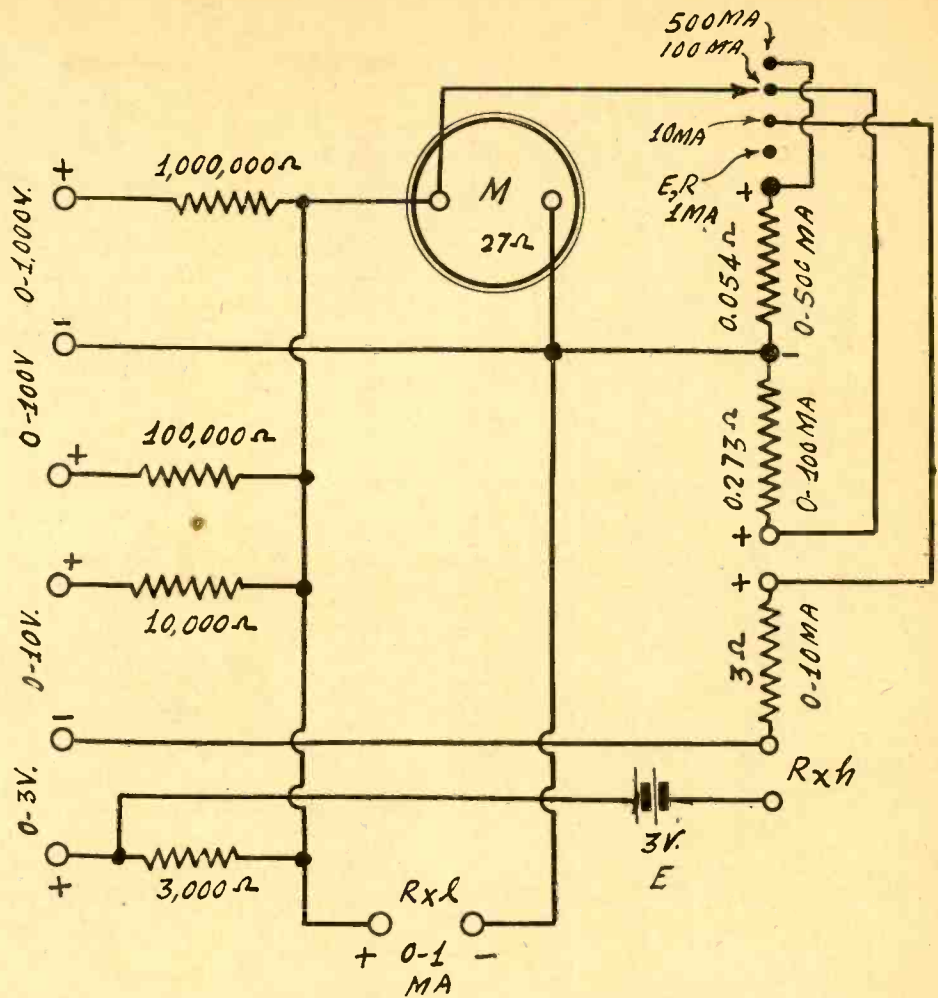

**A handy meter assembly, for measuring d-c voltages, 0-1,000, 0-100 and 0-10 volts, d-c currents, 0-100, 0-10 and 0-1 milliamperes, and resistance values from 100 ohms to 100,000 ohms. Lower resistances may be read by shorting the  $R_x$  terminals and putting the unknown across 0-1 ma.**

Some will not like the voltage and current scales used, but may change the instrument to suit. The reason for selecting 1,000 volts is not that any voltages nearly as high as that are likely to be read, but so that greater accuracy will prevail in reading voltages of a few hundred volts, due to the lesser current drawn by the meter when the 1,000-volt scale is used. The voltage distribution in lower values is ample, as the next range of 100 volts and the next one of 10 volts. The 3-volt scale, it is expected, will be used rarely, and so the necessary computation is not troublesome.

The switch may be of the snap type, or the regular single-pole multi-throw type, where, if the throws are more than four, extreme end ones would be used for off positions. The switch is required, to get rid of shunts for all voltage and resistance readings.

**Box Provisions**

Any who desire to calibrate the meter-shunting unknown resistances may do so by using a known high current and the 100-milliamperes or 500 milliamperes scale of the regular current meter. Thus the resistance of the unknown low resistance would be the voltage across it (also measured by the same meter used as voltmeter) divided by the current in amperes. When a group of low resistances of suitable range is selected, and currents noted by shunting, a curve may be run, although there will be on improvement in the use of that method as compared to following the table just given.

The box may have rubber feet glued to it, at the four bottom corners, and the two calibrations then may be glued to the bottom of the box so that they would not scrape against any table or other resting place. That is accomplished by measuring the distance easily cleared inside the rubber feet, and having each calibration scale a bit less than half of the area. Then to consult the curves simply turn the box upside down. This is a better method than tampering with the meter scale.

**Multipliers and Shunts**

The series multipliers had better be commercially wire-wound resistors, unless you

feel you can do this work yourself, winding half the number of turns in one direction and the other half in the other, so as to get rid of the inductive effect. The wire is insulated manganin.

The current shunts can be made by the experimenter. A table herewith gives the average resistance per linear inch for various diameters of wire, and of course applies to all types of insulation. Approximately the length needed may be obtained by dividing the resistance per linear inch, as obtained from the table, into the required resistance for the shunt as read from the diagram. Two precautions are necessary. For the heavy current shunts, 500 and 100 milliamperes, a wire size that will handle the current without heating is required, and also all joints must be carefully soldered, and all flux removed, using alcohol and rubbing smartly with a strong cloth.

Let us work out three examples for the current shunts. The highest current will be for 499 milliamperes through the shunt when there is 1 milliamperes through the meter, making a total of 500 milliamperes. Nearly every one has some bell wire (annunciator wire) around the house or shop, and as this is No. 18, let us select it.

**Establishing Accuracy**

The resistance per inch is 0.006385, the required resistance is 0.054 ohm, and so we will need a little more than seven inches. Let us select 8 inches, use that as shunt when a known current is flowing, for safety not more than half of the full-scale (250 milliamperes allowed). As there is a little too much shunt resistance, more current will flow through the meter than should, and the reading will be too high, so the wire is cut down, bit by bit, and tested each time, until the reading is just right.

For 100 milliamperes the shunt should be 0.273 ohms, approximately, and using No. 28 enamel wire, 0.0649 ohm per inch, a little more than 4.2 inches would be necessary, so use 3 inches, test on a current not more than half of the full-scale (not exceeding 50 ma) and reduce the wire length gradually as before until accuracy is established.

For the 3-ohm shunt, for 0-10 ma. No. 30 wire may be used, of which about 10 inches will be needed, and will be cut down experimentally as in the previous instances.

The wire that extends for any length, as 8 and 10 inches in two examples, may be coiled on a dowel. No attention is paid to non-inductive winding. Depending on the distance between meter terminals, the wire size will have to be selected for 100 milliamperes, for instances, so that the total length will be at least as great as the distance between the posts, but 4.2 inches, as applying to No. 28 enamel wire, is ample for practically every meter.

**Table of Resistance Per Inch**

The wire-resistance table follows:

B & S Gauge	R per Inch	B & S Gauge	R per Inch	B & S Gauge	R per Inch
14	0.002525	23	0.02036	32	0.1641
15	0.003184	24	0.02567	33	0.2069
16	0.004016	25	0.03237	34	0.2609
17	0.005064	26	0.04081	35	0.329
18	0.006385	27	0.05147	36	0.418
19	0.008051	28	0.0649	37	0.5231
20	0.01015	29	0.08183	38	0.6596
21	0.0128	30	0.1032	39	0.8318
22	0.01614	31	0.1301	40	1.049



## LIST OF PARTS

### Coils

- Four antenna transformers, wound as directed, and enclosed in shield not less than 4 inches across.
- Four interstage transformers, wound as directed, and enclosed in shield not less than 4 inches across.
- Three shielded 10 mh. choke coils.
- One dynamic speaker, with field coil built in (resistance from 1,800 to 2,500 ohms), and output transformer for single pentode.
- One power transformer, standard 2A5 type.

### Condensers

- One two-gang 0.00014 mfd. tuning condenser.
- One midjet manual trimming condenser (three plates sufficient).
- Seven 0.01 mfd. mica fixed condensers.
- One 1.0 mfd. paper dielectric fixed condenser.
- Two 50 mmfd. fixed condensers.
- Two 10 mfd. electrolytic condensers (30 volts rating).
- Four 8 mfd. electrolytic condensers (500 volts rating).
- Two 0.05 mfd. fixed condensers.

### Resistors

- One 400-ohm resistor.
- One 500-ohm resistor.
- Two 0.05 meg. resistors.
- One 3,500-ohm resistor.
- One 1.0 meg. resistor.
- Two 0.1 meg. resistors.
- One 5,000-ohm resistor.
- Two 5.0 meg. resistors.
- One 0.25 meg. resistor.
- (Above are 1-watt pigtail resistors.)
- One 250,000-ohm potentiometer with a-c switch attached.

### Other Requirements

- One chassis, 3x10x8 inches.
- One vernier dial, pilot lamp and escutcheon.
- Two grid clips.
- One four-pole, four-throw switch, insulated shaft type.
- Three six-hole sockets, two five-hole sockets and one four-hole socket (extra UY socket is for speaker plug).
- Three tube shields (for 58, 57 and 56).
- One 1-ampere fuse with holder.
- One a-c cable and plug.

direction, tickler below grid coil, top of grid winding goes to G, bottom of grid winding to grounded B minus. Beginning of tickler toward B plus (2) and end of tickler to plate (1).

If these directions can not be readily followed, simply connect the tickler one way and determine if there is oscillation, by advancing the regeneration control, and if no such result is obtained, reverse the tickler connections, putting to plate the lead formerly connected to resistor, and to resistor the lead formerly connected to plate, and since regeneration now can be obtained, observe the same polarity connections for the windings—primary, secondary and tickler—for the other coils as in the first instance.

There is really no problem here, and the experimental advice covers everything. Adding further explanations would simply darken the thought and perhaps even discourage the effort.

### Regenerative Factors

The regeneration in the detector stage depends on factors other than the tickler connections alone. However, with the constants selected as directed, there will be regeneration, and the only consideration would be whether the regeneration might be pressed a bit farther to advantage. To increase the regenerative action a shorter aerial may be used, or a small series condenser in the antenna circuit (less than 0.0001 mfd. preferably), a larger value of

grid leak (particularly if a dead spot or two develop) and the plate load resistor (0.25 meg.) or screen series resistor (0.1 meg.) may be lowered, either one or, in extreme cases both. Also, the bypass condenser from plate choke to ground in the detector circuit, the left-hand 0.00005 mfd. condenser (50 mmfd.) may be increased in value to 0.0001 or 0.00025 mfd., but the reason for leaving it as low as 50 mmfd. is that the higher audio frequencies are well preserved in the amplification, since much larger capacities across a high resistance like 0.25 meg. create a serious shunt condition from an audio aspect.

The grid leak in the driver stage is very high, 5 meg., as the 56 type tube will stand this, although in the next stage the lead is 1.0 meg., which is as high as the tube manufacturers recommend, due to the danger of grid current causing the output tube to lose bias.

### Check on Bias Loss

It is always well to check up the effect of the leak used in this circuit, which can be done by putting in a loud signal and noting what happens to the 2A5 plate current. It should not rise to much more than 45 milliamperes on the strongest signal you would receive. If it goes to 60 ma or so it is a sure sign the leak has to be reduced.

In reality the leak, as a d-c function, consists of 1,100,000 ohms, due to the 100,000 ohms in the auxiliary hum filter (0.1 meg. and 0.1 mfd. across it).

The condenser marked 10 mfd. up, across the 5,000-ohm biasing resistor of the 76, may not be necessary, depending on impedance factors in the speaker and B choke. Sometimes there is enough audio feedback to render the inclusion of a large condenser here impractical and unnecessary, but this can be determined experimentally, although as high a capacity as possible should be used, to just below the point where there would be motorboating. This is practically the same familiar advice found in directions concerning the use of regeneration, that the tube should be operated just below the oscillation point for utmost sensitivity. The motorboating of audio amplifiers is simply audio-frequency oscillation. So the principle is the same, although the frequencies are vastly different.

The same 2.5-volt winding may be used for all the four receiver tubes, but in the event you have two 2.5-volt windings on a transformer, use the larger-current one (A) for the three tubes and the smaller current one (B) for the output tube. If the 5-volt winding has a center tap, use the tap for output.

### Hum Kept Very Low

Hum is always something worth serious consideration in a short-wave set, but since the trouble is largely that concerning carrier modulation, two condensers of 0.01 mfd. capacity or higher, from line to ground, will take care of that, if the regular B filtration is ample. This it will be with the B choke equal in inductance to the average found in dynamic speakers, if the usual 8 mfd. filter capacities are doubled. The hum reduction is very pronounced in a short-wave set if this capacity doubling is utilized. But as electrolytic condensers likely will be used, and their impedance may be high to short-wave frequencies, a mica condenser of as large a capacity as at hand should be used, no less than 0.01 mfd., across the output 16 mfd. You may have to put two or three mica condensers in parallel to build up the capacity sufficiently to get rid of instability caused by high impedance here, or hum introduced as modulation at the carrier frequency of such oscillation.

The circuit has only five tubes, but the sensitivity is sufficient for the usual excellent performance of such a regenerative set when the parts are properly selected, coils carefully made, shielding not too close, and proper voltaging applied.

### Reducing B Voltage on 58

The B voltage available at the output may

run around 300 volts, due to the 16 mfd. next to the rectifier, which would be all right for the power tube, driver and even the detector, but would be too high for the r-f amplifier, so a series resistor of around 5,000 ohms should be used to reduce the B feed to the first tube, no extra bypass condenser being needed, as the one from the r-f choke in this leg serves the purpose.

Strange as it may seem to some who have not had much experience with the tubes used in this set, the gain may be more than can be handled, and there would be oscillation even without carrier input. This is a mild form of instability but one that should be overcome, and an easy way is to put a resistor of 50,000 ohms or so in series with the 1.0 meg. in the 2A5 grid circuit, connecting grid to the joint, and other end of the 50,000-ohm unit to the 0.05 mfd. stopping condenser. The greater this extra resistance the more the stabilizing effect, but do not press this remedy to the point where it begins to be a disadvantage.

### Fuse the Line!

The line is fused, and this precaution always should be followed. It is too bad there is a dearth of small fuses and holders, but they are obtainable, and any one interested may get the necessary information by addressing Trade Editor, RADIO WORLD, 145 West Forty-fifth Street, New York City.

### Coil-Winding Information

The tuning capacity used is a two-gang 0.00014 mfd. condenser. It is assumed that the minimum capacity is 25 mmfd., so that if as much is added to the maximum the capacity ratio would be 165/25, or 6.6, the square root of which, or frequency ratio, is 2.57. However, part of the minimum capacity is in the condenser itself at the lowest capacity setting, and the maximum is always measured regardless of the minimum, so adding 25 to 0 in one instance and to 140 in the other does not give exactly the correct ratio, therefore instead of 2.57, a ratio of only 2.5 is used, and besides this affords the necessary overlap. The tabulation will not show the overlap, but it may be taken for granted, since the tabulation takes care of the frequencies you desire to cover, and will cover, and the overlap is mere surplusage.

Also, since what the extra capacities due to wiring, placing of parts, etc., can not be determined in advance, the inductance is selected on the basis of only 140 mmfd. maximum, and therefore the values will apply to condensers rated at 150 mmfd., as well as to circuits introducing extra capacities of unknown but allowed-for values.

The table of secondary information follows, for condensers of the capacities rated 140 and 150 mmfd. values:

kc	Inductance	Turns for 2" Diameter
1,500-3,750	70 muh	30 turns No. 28 enamel
3,750-8,375	11.2 muh	11 turns No. 22 enamel
8,375-20,937	1.79 muh	4.4 turns No. 18 enamel
20,937-42,342	0.72 muh	2.8 turns No. 14 enamel

Two forms are used for winding, the antenna coil windings on one form, interstage windings on the other, and enclosure made in two aluminum shields 3 inches in diameter.

### Primaries and Tickler

For primaries of the antenna coupler, the number of turns is about one-quarter that on the secondary, same diameter wire, and wound next to (not over) the secondaries, 1/16 inch separation between.

For primaries and ticklers of the interstage coil, the primaries have one-quarter the number of secondary turns, 1/16 inch separation, as before, but the wire may be much finer, and the ticklers for the two lower frequency bands have one-quarter the secondary turns, fine wire permissible; for the second from highest frequency band, as many tickler turns as secondary, while the highest band requires a tickler with of two or three more turns than the secondary, separation as before.

The value of the load resistor in the plate  
(Continued on next page)

# AUDIO DISTORTION

## Its Elimination Requires Sufficient Filtration

By Einar Andrews

**Q**UANTITY of reproduction of radio signals is as much in demand now as ever, but little is done about it. Much is done against it, on the other hand. The economic depression seems to be the reason for the departure from good quality. The highest quality cannot be obtained from a receiver that costs the least money.

There may be considerable distortion in an amplifier because of lack of adequate by-passing or filtering in the supply leads. This distortion is less severe the fewer stages are used in the audio amplifier, for there will be less feedback. It would seem, therefore, that an amplifier consisting of a triode or pentode voltage amplifier and a triode or pentode as power amplifier would give good quality. At least it will not cause much distortion as a result of feedback. The first amplifier may be the triode or pentode in a duplex diode type of tube. Since such amplifiers, that is, a stage of voltage amplification and a power stage, are used in many of the smallest receivers, these have one point in their favor.

### Common Impedance

In Fig. 1 is a simplified amplifier of the type that may occur in such receivers. There is a plate load resistance  $R_1$ , a stopping condenser  $C$ , a grid leak  $R_2$ , and a load impedance  $Z_1$  on the power tube. The impedance of the B supply is represented by  $Z$ . It is assumed that the condensers across the bias resistors are large enough to prevent any reverse feedback in each stage.

It is the impedance  $Z$  that causes trouble if this is not low enough. Of course, there is always a condenser across the output of the B supply, and this reduces the value of  $Z$ . But the condenser may not be large enough. If we assume that the stopping condenser  $C$  is large and also that the grid leak resistance  $R_2$  is large, then these two do not have much effect on the amplification, except on the very lowest and on these it will reduce it.

If we assume that the amplification factor of each tube is 100, that the internal resistance of the first tube is 800,000 ohms, that of the second tube 7,000 ohms, that  $R_1$  is 250,000 ohms, and that the load on the second tube is a pure resistance of 7,000 ohms, the amplification in the entire amplifier is  $1,335/(1.12 + Z)$ . At a very high frequency the value of  $Z$  is entirely negligible even if the by-pass condenser across the B supply is only one microfarad. Hence the high frequency amplification is 1,190. At the lowest audio frequency, say 25 cycles per second, the reactance of a condenser of one microfarad is 6,360 ohms. Thus at this frequency 1.12 is negligible in comparison and the amplification is only  $1,335/6,360$ , or 0.21. That is, there is a loss instead of a gain.

If we increase the by-pass capacity to 8 mfd., the reactance, which may be taken as the value of  $Z$ , is 795 ohms, and the gain becomes 1.7 times at 25 cycles per second. With the 8 mfd. condenser the gain is reduced by 50 per cent. at 1,200 cycles per second.

### Prevention of Loss

It is clear that the gain from the amplifier is not nearly as high as it is thought to be even when the by-pass condenser is the largest value that is usually employed. Hence it is of first importance to have a means of preventing the reverse feedback. This means is very simple. If a resistor, say 50,000 ohms, is connected in series with  $R_1$  and then a condenser of one microfarad or more

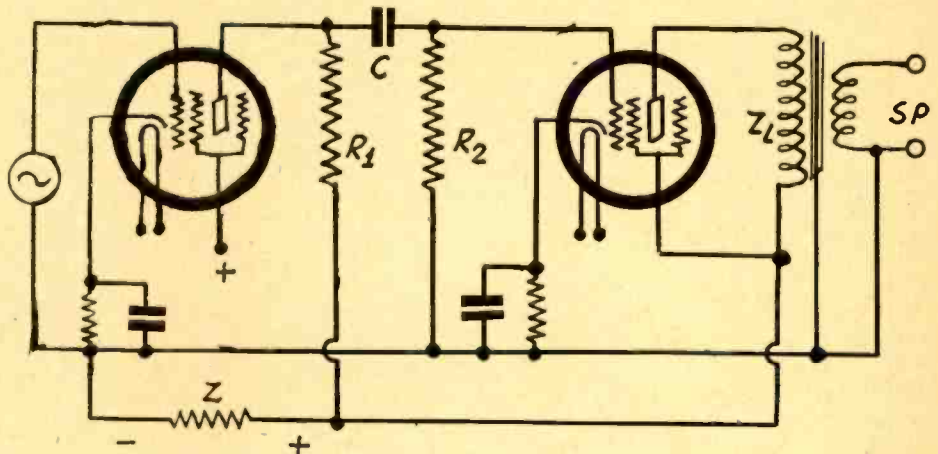

FIG. 1

This circuit illustrates why certain audio amplifiers oscillate or distort. The impedance  $Z$  is common to all the plate circuits and will cause regeneration or degeneration according to the type to circuit.

is connected between the junction of these resistors and ground, most of the reverse feedback is eliminated.

In a two stage amplifier like the one in Fig. 1 the filter is often omitted because the circuit does not motorboat when it is. It is only included when there is hum. The absence of the low notes is not realized. The presence of the high notes may be realized by the amount of hiss and tube noises, and to eliminate this noise a tone control is included. But the tone control reduces the gain on the high frequencies, it does not increase it on the low. It would be better to use the filter and thus to build up the gain on the low frequencies.

### Alternative Method

There is an alternative method of building up the gain on the low notes. If another stage is added to the amplifier and all the three plates are put on the same B supply, as is usually done, the impedance  $Z$  causes regeneration. If correct values, which must be determined in each case, are used the regeneration can be placed at a very low audio frequency and so adjusted that the circuit will not motorboat. If the maximum

regeneration is at 25 cycles, and the circuit will not oscillate at that frequency, the gain due to regeneration will be about in inverse ratio to the frequency, measured upward from that point, and the total gain in the amplifier will be about equal at all frequencies.

Adding another stage has the disadvantage of adding more wave form distortion in the amplifier, that is, it will make the harmonics stronger. Adding a stage of push-pull will not help the frequency distortion, unless the push-pull stage is unbalanced, and then it will not prevent the generation of harmonics. Moreover, the push-pull stage, if unbalanced, might increase the frequency distortion just as well as reduce it.

### Rules for Regeneration

If the circuit is direct coupled the circuit will be degenerative if there is an even number of plate on the common impedance and it will be regenerative if there is an odd number. This rule may be upset if the stopping condensers and grid leaks are such that there will be a considerable phase change in them. Regardless of what these values are, if the frequency is low enough there will be sufficient phase change to upset the rule. Thus a circuit having three stages can be degenerative and one having four may be regenerative on the low frequencies. A two stage amplifier is rarely regenerative. When the amplifier is transformer coupled, the same rule applies if the mutual inductance between the windings is positive. The rule is reversed if the mutual is changed.

It is because of this fact that a transformer coupled amplifier that oscillates can often be stabilized by reversing windings. Sometimes reversal of one pair of leads will only change the frequency of oscillation, but if the change is from a low to a high frequency, there is a gain because at the high frequency by-pass condensers will be effective in reducing the common impedance to the point where there will be no oscillation, or even appreciable regeneration or degeneration.

## Regenerative Receiver for the Short Waves

(Continued from preceding page)

circuit has an effect on regeneration, and if there is absence of regeneration over part of the dial for any coil, this resistance may be lowered until there is regeneration all over the band. Then the same favorable condition will prevail for the other bands, with the single exception that a supposedly high grid leak in the detector really may be too low, because of inaccuracy of marking or rating, and several leaks may have to be tried, or preferably measured, until one reaching 5 meg. or more is actually obtained. Also, regeneration can be made keener, if desired, by using a series condenser in the antenna circuit permanently there, of 0.0001 mfd. or small capacity.



# A MODERN CONVERTER

DEVICE WORKS INTO EITHER T-R-F SET OR SUPER TO OPEN SHORT-WAVE REALM OF THRILLS TO OWNER OF BROADCAST SET

By Herman Cosman  
Try-Mo Radio Corporation

A SHORT-WAVE converter properly constructed and designed opens up a vast realm of radio to any one who has a good or fairly good broadcast receiver. Just what is a short-wave converter? It is the high frequency part of a short-wave superheterodyne. It comprises a radio-frequency tuner for the short waves and oscillator for the frequency conversion. It may or may not contain a stage of intermediate frequency amplification. The regular intermediate frequency amplifier is the radio frequency amplifier in the broadcast receiver. This may also be a superheterodyne, in which case there are two frequency changes before the final detector.

The design of a short-wave converter follows the same rules as the design of a short-wave superheterodyne as it is subject to the same conditions. First of all, there must be a high selectivity in the high-frequency level, for otherwise it is not possible to reject all frequencies not desired and to receive only one.

This unitary condition is absolutely necessary if squeals are to be avoided, as in any other superheterodyne. The use of more than one radio frequency tuner would be desirable if it could be done practically. Having a choice of intermediate frequency, however, it is possible to avoid interference by making a slight change in the intermediate frequency when a squeal should happen to coincide with the signal desired.

### A Four-Tube Converter

The diagram shows a four-tube short-wave converter circuit which has been worked out carefully. As will be seen, the radio-frequency amplifier is a 58, and this is fed by a tuned circuit. The second tube in the converter is also a 58, but this is operated as an intermediate-frequency amplifier. This is coupled to the first tube, which is the mixer, by means of a tuned grid transformer, the tuning condenser being variable to permit changes in the intermediate frequency.

The oscillator is a 56, and the circuit is of the tuned plate type. The oscillator tuning condenser has a value of 140 mmfd. and it is ganged with the radio-frequency tuning condenser, which is also a 140 mmfd. unit. As the oscillator and radio-frequency circuits will differ considerably for lower signal frequencies, it is necessary to add another variable condenser in the radio-frequency circuit which is controllable separately. For that reason another 140 mmfd. condenser is shunted across the r-f condenser. The coils are so designed that when the gang condenser is set at minimum capacity, minimum value of the separately controlled condenser is needed. Then as the capacity in the gang condenser is increased and the frequency is lowered, the separately tuned condenser is brought into play to cause tracking.

This arrangement does not preclude calibration of the main condenser dial. It is calibrated in terms of signal frequency, although when set on the point indicated by the calibration neither the oscillator nor the radio frequency circuit is tuned to that frequency. It is tuned to a frequency which is less than the oscillator frequency by the amount of the intermediate frequency.

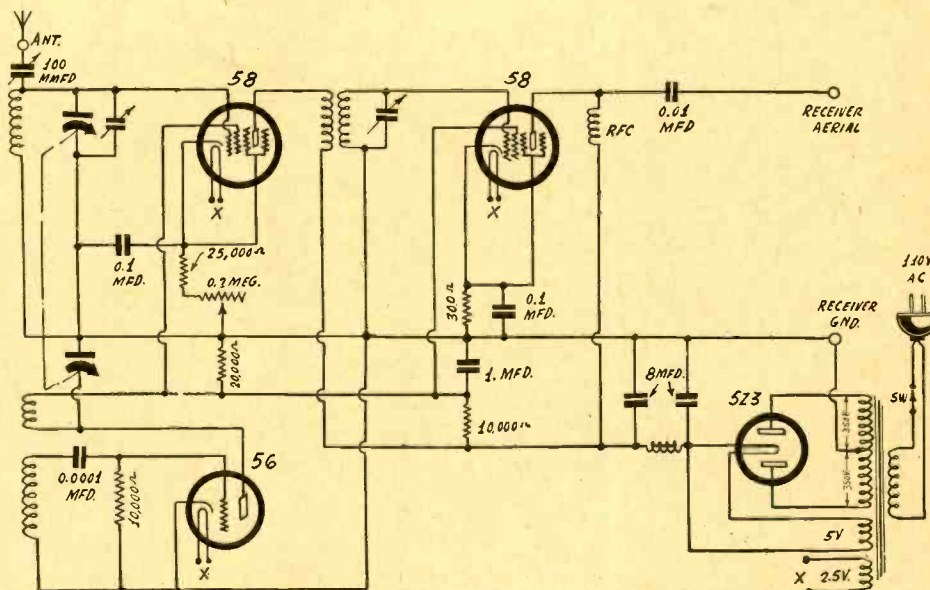

A short-wave converter that works into either a tuned-radio-frequency receiver or a superheterodyne. A variable intermediate is built in, for a stage of i-f ahead of the receiver into which it will work.

It is clear that the calibration must be effected for a given setting of the intermediate tuner. A suitable value can be selected and the position on the intermediate frequency dial marked. Then to pick up a given station it is only necessary to set the intermediate at this mark and to tune the gang condenser to the point indicated by the calibration. The separately controlled condenser is then brought into action to bring out the highest sensitivity.

This arrangement avoids all troubles incident to padding adjustments, for the circuit can always, and easily be brought into the most sensitive adjustment, and changes in weather will not upset it.

### Output Arrangement

The output circuit of the intermediate amplifier is arranged so that the output terminals of the converter can be connected safely to the antenna-ground terminals of the broadcast receiver in any case. The intermediate tube is fed by a radio frequency choke and in the "hot" lead of the output is a stopping condenser of 0.01 mfd. Best results will be obtained when the input to the receiver has a high impedance, and that is the usual case, even when an antenna transformer of low primary impedance is employed. It is the resonant impedance of the primary that counts, and not the inductive reactance of the primary.

The converter has its own power supply. Hence it is not necessary to enter the

broadcast receiver to locate a place where a positive voltage for the tubes of the converter can be obtained. A cable with line plug is provided for plugging into the nearest convenient outlet. The antenna ordinarily used for the broadcast set is transferred to the antenna post on the converter and the output terminal is connected to the antenna post on the set. The ground post on the converter is also connected to the ground post on the set, without removing the ground from that post. That is all that is necessary to connect the converter to the broadcast set.

There is a 100 mmfd. variable condenser in the antenna lead for the purpose of adapting the broadcast antenna to short waves and also to vary the volume of the output of the converter to some extent. It also serves to improve the selectivity of the high frequency circuit.

The regular volume control for the output of the converter is a 25,000-ohm variable resistor placed in the cathode lead of the mixer tube. This acts to vary the bias on the mixer.

Coupling between the oscillator and the mixer is effected by mutual inductance between the radio frequency and oscillator coils the two being placed on the same form, end to end, but separated by a relatively great distance.

Coil switching is done by a gang switch placed in the center of the coil assembly. This makes all the leads between the switch and the coils short.

# CHOICE ANTENNAS

## Inverted L and Plain T Types, Transposed Leadins, Loops and Coupling Impedances

By J. E. Anderson

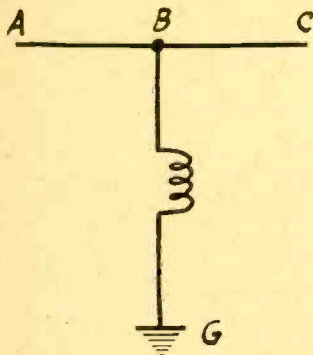

FIG. 1

Schematic of an antenna. When AB and BC are omitted, the antenna is the vertical wire type. When either AB or BC is omitted the antenna is an inverted L type. When both AB and BC are used the T-type results.

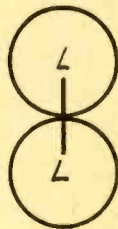

FIG. 2

Polar diagram of the reception pattern of a loop LL. There are two circles touching at the center of the loop.

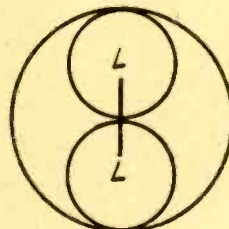

FIG. 3

The reception patterns of a loop, the two small circles, and that of a vertical wire, the large circle, are combined after the pickups have been accurately adjusted to equality.

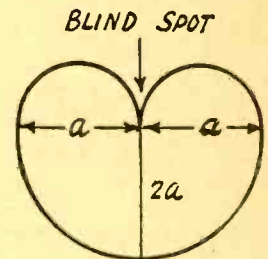

FIG. 4

This is the polar diagram of the reception pattern of a loop and a vertical wire. The figure is that of a heart, or cardioid. No reception occurs from the direction of the blind spot.

THE antenna is one of the most important elements of a radio receiving installation, for it is that which collects the signal. The signal voltage picked up is approximately proportional to the height, but this does not mean that the higher the antenna is the better reception will be. The impedance of the antenna also enters. The best height for a given frequency is such that the effective height is equal to one-quarter of a wavelength, for then the current near the ground, where the signal is picked off by means of a transformer, is greatest.

There are many different types of antennas, such as the vertical wire, the inverted L, and the T. Fig. 1 shows the T-type, in which GB is the lead-in or vertical wire and ABC is the flat top. If either AB or BC is omitted the antenna is of the inverted L type. If both AB and BC are omitted it is of the vertical wire type.

### Directional Qualities

The vertical wire antenna is non-directional. That is, it will receive equally well from all horizontal directions. The inverted L is slightly directional in that it will receive better from the direction opposite to that to which the flat top points. In other words, if AB is omitted, the reception will be better from the left; if BC is omitted, reception will be better from the right. The T-type antenna is also slightly directional in that it will receive somewhat better from directions at right angles to the direction of the flat top.

The loop is an antenna, or coil collector of signals, that has marked directional qualities. The greatest pickup occurs when the

plane of the loop points in the direction of the station from which the waves come, assuming that the waves travel in straight lines. At right angles to this direction there is no reception.

This assumes that the loop antenna is not also a vertical wire antenna, which it usually is to a slight extent. When there is a small "antenna effect" in the loop, reception will not be the same from both directions but will differ slightly depending on which edge of the loop points to the station.

### Producing Blind Spot

By combining a vertical wire antenna and a loop in the proper way, it is possible to arrange the reception pattern so that when one edge points to the station there is no reception at all and when the other edge is put forward the reception will be maximum.

The proper arrangement is illustrated in Fig. 3. The large circuit represents the reception pattern of the vertical wire antenna. It is a circle because the vertical wire receives equally well from all directions. The two inner circuits, or the figure 8, inside the large circle represents the reception pattern of the loop. At right angles to the loop there is no reception and in the line LL the reception is maximum. Now when the vertical antenna and the loop work together and when the loop picks up exactly the same amount of signal from one direction as the vertical wire does, the combined reception pattern will be that of a heart as shown in Fig. 4. The pickup will be doubled in one direction and will be completely neutralized in the opposite direction.

This blind spot is often utilized in eliminating interference from a strong local sta-

tion. If the blind spot is pointed to the local station there will be no reception from it, nor from any other station lying in the same direction, but there will be considerable reception from stations lying in any other direction. Of course, reception will be weak in directions differing but slightly from that direction.

### Transposed Leadins

Transposed leadins are often used for the purpose of eliminating noise originating in the building where the receiver is located. These permit the installation of an antenna high on the roof where there is comparatively little noise and leading the signals to the receiver by a line that does not pick up any additional signals, whether these signals be desired ones or merely noise. The transposed leadin is only a form of shielded transmission line and such a line may be used as well. The transposed leading form of line is simpler to construct and for that reason it is used. The transposition of the two wires is done at intervals of about one foot by means of transposition blocks where the wires can be crossed, and these blocks are made of good insulating material.

A transmission line should be terminated at each end, that is, at the antenna and receiver ends, by suitable coupling transformers which must match the impedances, first the impedance of the antenna to that of the line and then the impedance of the line to that of the receiver input. In order to get the best matching the radio frequency transformers employed should be provided with a variable ratio so that the matching can be done experimentally. It will suffice that taps be put on one side of the transformer

# Transmission, Counterpoise and Doublet

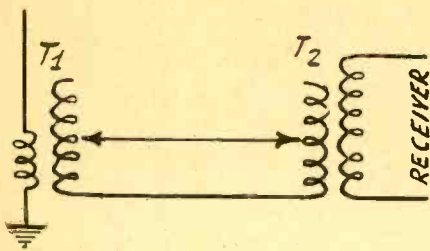

FIG. 5

A transmission line, such as a shielded cable or transposed leadins, should be matched to the antenna and the receiver by means of suitable transformers T1 and T2.

only, preferably on the line side in each instance. How this may be done is illustrated in Fig. 5 in which T1 is the antenna-to-line transformer and T2 is the line-to-antenna transformer.

## Shielded Line

When it is necessary to eliminate as much noise as possible, the transmission line between the antenna on the roof and the receiver down in the building should be shielded. That is, it should consist of two concentric conductors with the outside one grounded. The grounding should be done at both ends, that is, both at the antenna and receiver end, and it may be grounded at many points between.

This method of leading in the signal is employed in large apartment houses and hotels. There are cables available that are suitable for this purpose. One in particular is the cable employed in automobile receivers which consists of an inner conductor inclosed by an outer sheath, the two being separated by a thick serving of cotton. But this is not suitable in most places. There is also a shielded cable in which the insulation between the two conductors is soaked in wax and there is also a waxed insulation cover over the outside conductor. This is more suitable where moisture is involved.

## Best Antennas

Just what constitutes the best antenna for any set depends on many factors. The sensitivity of the receiver is involved. So is the selectivity. An antenna that picks up the maximum signal from the air may not be as good for a very sensitive set as one that does not pick up so much. Likewise, a good antenna as such may not be the best for a receiver that is highly sensitive but not selective. For example, a superheterodyne may work very well on a small antenna that does not pick up much, but it may be entirely unsatisfactory when the antenna is a good collector, for there may be too many squeals to make the receiver practical. This is the reason why a short antenna often gives better results than a long one. The antenna may be "shortened" by putting a small condenser in series with it, and that is the reason why the antenna condenser often improves a set.

## Practical Limitation

If the set is very sensitive—and most modern sets are—it will work on an antenna consisting of a wire a few feet long. The amplification in the receiver is so high that if anything is picked up at all there will be ample output in the loudspeaker. But there is a practical limit to this. The greater the amplification in the receiver the greater will be the tube noises. Therefore the antenna

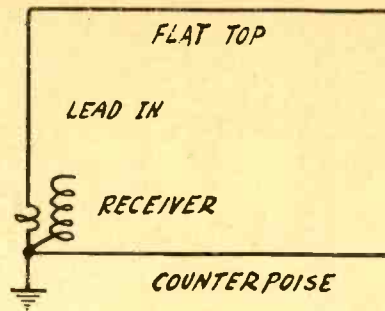

FIG. 6

An antenna and a counterpoise showing where the ground may be connected. The counterpoise wire or wires should not be grounded at any other point.

should be sufficient in length to bring in most stations regularly received without any noise, that is, it should be sufficient to permit the operation of the receiver far below its maximum amplifying efficiency. This is not a severe limitation because the noise level is usually so slow that stations within a 1,000 miles can be received noise free if the antenna wire is a few feet in height.

## Use of Counterpoise

A counterpoise is a device often used in receivers as well as in transmitters. To explain this, let us first discuss the doublet antenna. Suppose we have a long wire and in the exact middle of it we put a small coil for coupling to a receiver or transmitter. One end can then be regarded as the antenna and the other as the counterpoise. Practical and symmetrical doublets can be used for the reception of horizontally polarized waves, for then the two ends of the antenna can be mounted horizontally.

When the waves are vertically polarized, it is not possible to have a symmetrical arrangement unless the entire vertical wire is raised far above the earth. It is when the vertical wire is close to ground that the other wire is called the counterpoise. It then consists of a single wire near ground but insulated from it and located directly under the horizontal portion of the antenna, then consists of a single wire near ground far wires, and they may radiate in all directions.

The idea is to form a condenser of low resistance, the horizontal portion of the antenna being one plate and the counterpoise the other. The two plates are connected by the leadin in which the primary of the input transformer to the receiver is connected near the counterpoise.

Such a device has a low resistance and is therefore effective as a pickup. The radiation resistance need not be low. In fact, it should not be. The antenna and counterpoise are illustrated in Fig. 6. Note that there should be one ground connection. The doublet is illustrated in Fig. 7. In this, the midpoint on the primary can be grounded.

## Erection of Antenna

Much has been said about the proper way of erecting an antenna. We have been told that the antenna wire should be high above the top of the building, far removed from trees and other obstacles, at right angles to all other antennas and electrical wires in the neighborhood, and that it should be well insulated and firmly mounted. No doubt all these precautions should be taken when the very best antenna is to be erected. But most of them are of merely theoretic interest because in most instances it is simply impossible to meet the requirements. And in most cases also they are ignored out of necessity.

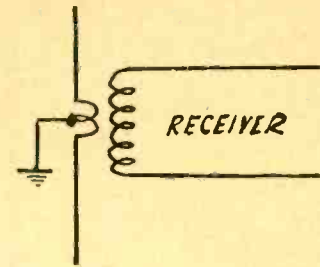

FIG. 7

The doublet antenna, showing where it may be grounded. Ordinarily the doublet is used for the reception of horizontally polarized waves. It is popular for short waves.

There are instances, however, where they can be observed and where they are observed. There are a few who are fortunate enough to be living in the country where there is ample space.

The injunction that the antenna should be well insulated can be obeyed in any case, and that is one of the most important. Also that of firm mounting is not difficult to obey. The leadin should not be allowed to rub against the building or against anything but should be held firmly by its insulators. Outside wires should either be weatherproof or they should be bare or enameled. Any moisture absorbing insulation is detrimental to good reception. Any rubbing of wires against anything will give rise to noises, for it will be a loose connection. The entrance of the antenna from the outside should be well insulated, and this is not difficult to comply with. It is advisable to employ a drip loop just outside the entrance so that any water which may follow the wire will not be led into the house, but will be stopped by the drip loop. This practice is used in telephone installations and it is just as good for an antenna as for a telephone line. A drip loop is a kind of trap for rain water which comes down the antenna and is merely a bend in the wire the lowest point of which is lower than the entrance of the wire into the house.

## Reason for Insulation

It is, perhaps, better to use an insulated wire, provided that the insulation is good, for if the wire is allowed to corrode it will gradually deteriorate. Moreover, there is less chance of noise from accidental rubbing when the wire is insulated. But rubbing can be prevented by local insulation and by firm mounting where there is any danger.

Even when a shielded leadin line is employed, it is important to mount firmly, for if the outside conductor rubs against a metal noises will get into the line. This effect will be smaller the greater the number of places at which the outside condenser is grounded.

As a means of making the resistance of the antenna wire low, heavy gauge wire should be employed. It should not be smaller than No. 14, B&S.

## LITERATURE WANTED

- W. C. Haigh, 58 Newfield St., East Orange, N. J.  
 R. G. Killeen, 5762a McPherson Ave., St. Louis, Mo. (short-wave converters).  
 David Benk, 52 Mariposa Ave., Toronto 9, Ont., Canada.  
 Oral R. Hopkins, Higginsville, Mo.  
 Jack Sparrow, Jr., Ashley P. O., Sask., Canada.  
 R. C. McCullough, LaGrange, Missouri.  
 David Knopf, 1135 Forest Ave., Bronx, N. Y.  
 S. T. Yager, Owensboro Storage Battery Co., 317 West 4th St., Owensboro, Ky.  
 A. Brown, Box 302, Beverly Hills, Calif.  
 A. N. Lump, 4413 N. 7th St., Philadelphia, Pa.  
 Jos. Belick, 65 Front St., Box 133, Coplay, Pa.  
 D. E. Krause, 1382 Virginia Ave., Columbus, Ohio.  
 Carl J. H. Coleman, R. 6, Box 790, Sacramento, Calif.



# SHORT-WAVE SET CONSTRUCTIONAL PLAN

Sharon  
Company

## LIST OF PARTS

### Coils

One set of eight plug-in coils.  
One radio frequency choke, 8 millihenries.  
One 30-henry filter choke.  
One small dynamic speaker with 2,500-ohm field coil.  
One power transformer.

### Condensers

One gang of two 140 mmfd. Hammarlund condensers.  
Five 0.02 mfd. condensers.  
One 0.00025 mfd. condenser.  
One 0.001 mfd. condenser.  
One 0.1 mfd. by-pass condenser.  
One 0.5 mfd. by-pass condenser.  
One 25 mfd., 35 volt, electrolytic condenser.  
Two 4 mfd. electrolytic condensers, 500 volt rating.  
One 8 mfd. electrolytic condenser, 500 volt rating.

### Resistors

One 300-ohm bias resistor.  
One 3,000-ohm bias resistor.  
One 400-ohm bias resistor.  
One one-megohm grid leak.  
Three 200,000-ohm resistors.  
One 50,000-ohm resistor.  
One 80,000-ohm resistor.  
One 50,000-ohm potentiometer with line switch.

### Other Requirements

One drum dial with knob and pilot light.  
Seven sockets.  
Two grid clips.  
One tube shield.  
One two-compartment metal shield.  
One chassis.  
One metal box containing metal front panel and escutcheon.  
Cable and plug.

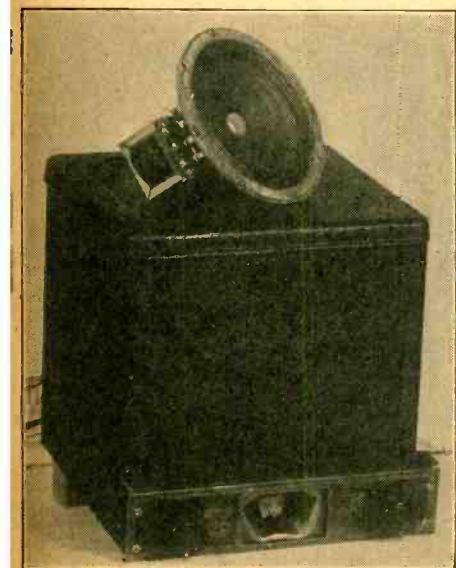

FIG. 2

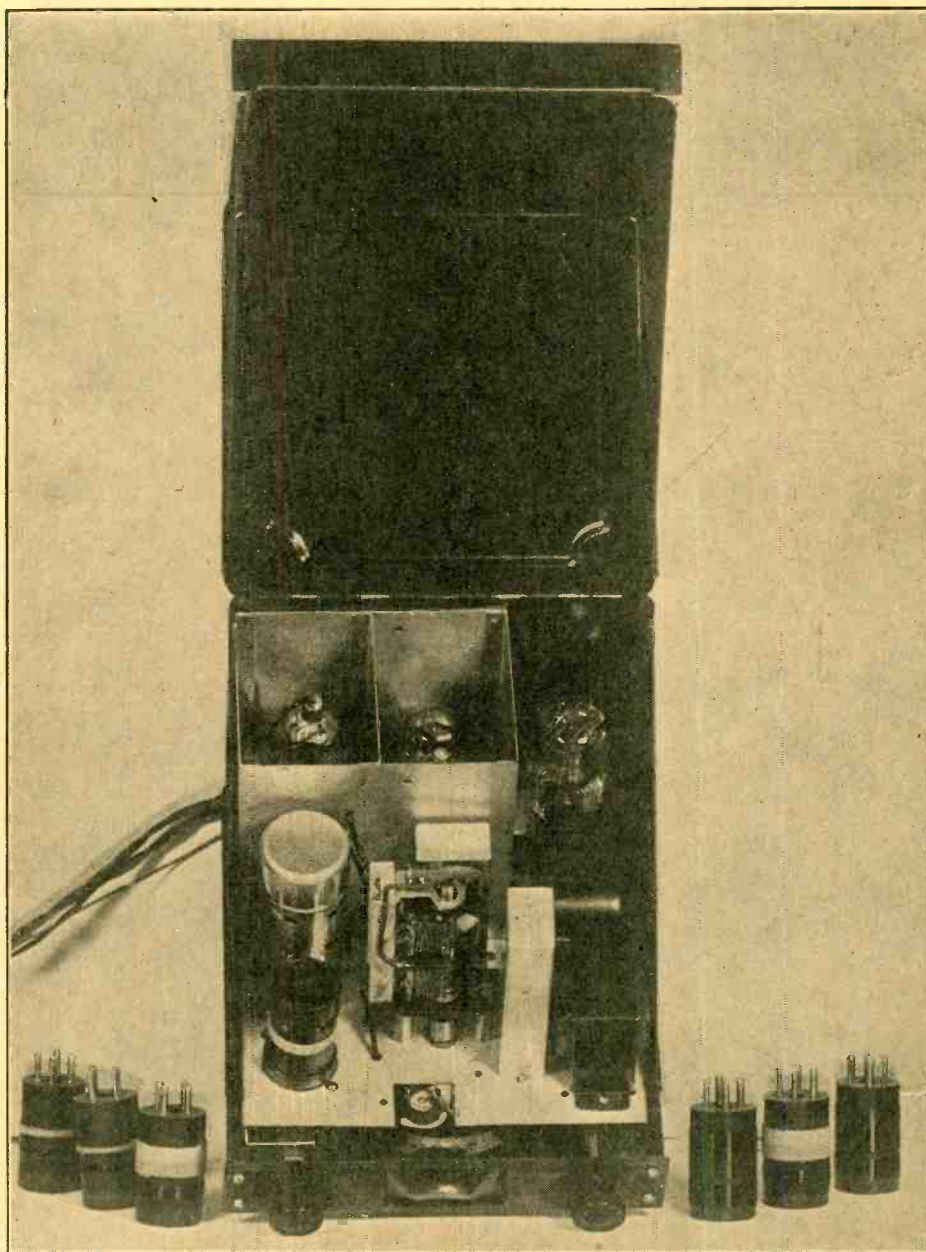

FIG. 3

A view of the short-wave receiver as it appears when the lid has been thrown open and the internal arrangement of the parts is disclosed.

ping condenser type. The condenser has the usual values and the grid leak a resistance of one megohm. In the plate circuit of the detector is a radio frequency choke and a by-pass condenser of 0.001 mfd., connected from the tickler coil to ground.

The voltage for the screen of this tube is obtained from a voltage divider connected between the high voltage lead and ground. This divider, which is the only one in the circuit, consists of a 200,000-ohm fixed resistor, on the high voltage side, and a 50,000-ohm potentiometer on the ground side. The screen is connected to the slider of this potentiometer. Hence the screen voltage

can be varied between zero and about 50 volts, assuming that the high voltage is 250 volts. A by-pass condenser of 0.1 mfd. is connected from the screen of the 57 and ground to insure by-passing of audio as well as radio frequency currents.

The detector tube plate is fed through a 200,000-ohm coupling resistor. Following this is a 0.02 mfd. stopping condenser and another 200,000-ohm resistor for grid leak.

A 3,000-ohm bias resistor is used on the 56 tube, and it is shunted by a condenser of 0.5 mfd. In the plate circuit of the 56 is a coupling resistor of 50,000 ohms, a stopping condenser of 0.02 mfd., and 100,000 ohms.

# A NEW COMBINATION

## Of Glow Discharge Oscillator and a Photo-Electric Cell

By Melchor Centeno, V., E. E.

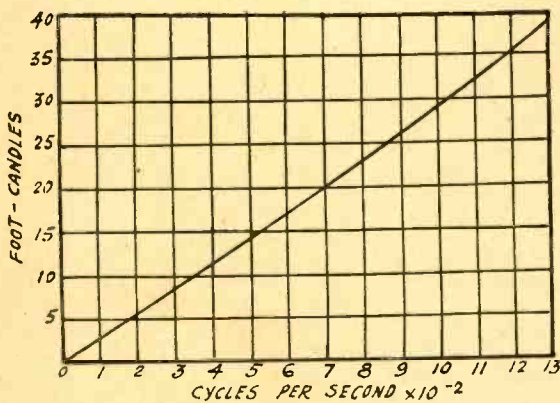

FIG. 1

Calibration curve, showing hundreds of cycles per second plotted against foot-candles. The linearity of the curve is obvious. Thus the oscillation frequency and light intensity are directly proportional.

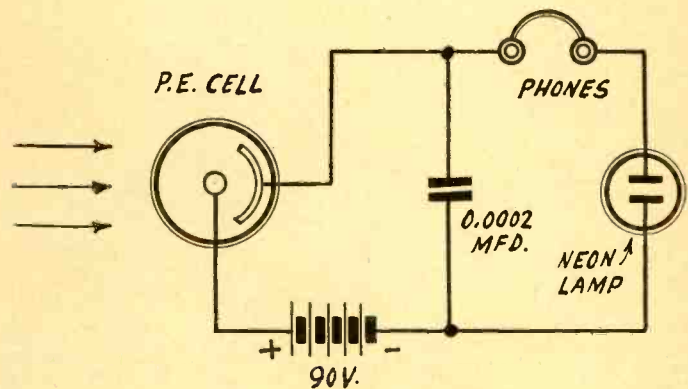

FIG. 2

A glow discharge oscillator (neon lamp), working with a photoelectric cell, the resistance of which changes with input light values, thus changing the oscillation frequency.

**E**VERY clever application of the glow discharge oscillator is due to Melchor Centeno, V., of New York City, who has issued a little booklet describing the device and suggesting a number of applications. As is well known, the glow discharge tube can be made to oscillate in a suitable circuit because one voltage is required to start the glow and a lower voltage to extinguish it. The oscillation occurs between these two voltages.

The interesting application of the glow discharge tube by Mr. Centeno is the combination of the oscillator with the photoelectric cell, or with any light sensitive device. As is known, when the light that enters the cell varies, the current through that cell, under the influence of a voltage, varies, and this means that the internal resistance of the cell varies.

The glow discharge oscillator requires the combination of a resistance and a reactance, usually that of a condenser. The frequency of the oscillator is determined by the resistance and by the capacity of the condenser. Approximately, the frequency is determined by  $f = 1/RC$ , in which  $R$  is the resistance and  $C$  the capacity of the condenser. If either  $R$  or  $C$  is varied the frequency is varied.

Now in the Centeno oscillator the resistance involved is that of the photoelectric cell or other light sensitive device. Since this resistance varies with the light that enters, the frequency of the oscillator varies with the intensity of the light. A large number of useful applications of such a device can be thought of.

One of the interesting points of such an oscillator is that the frequency of oscillation is very nearly proportional to the amount of light that enters the cell, since the plate

current in photoelectric cells is proportional to the light incident on the cell. This suggests the possibility of utilizing the device for measuring light fluxes or illumination and also of making light operate relays. A circuit can be tuned to a specified frequency which will be reached when the light attains a definite value. As soon as the oscillation frequency reached that of the resonant circuit the relay would trip. These are suggested by Mr. Centeno as well as many others. What follows is Mr. Centeno's own explanation of his interesting development:

### General Considerations

This new device is an improvement over the usual type of glow-discharge oscillators, permitting a greater elasticity in the control of the generated oscillating currents and making possible many new practical applications in the field of electronics.

In a general way it can be said that the device is a new form of transformer or converter, adapted to translate radiant energy values into corresponding frequency values of the generated oscillations. The radiant energy values refer not only to the quantity but also to the quality of the radiation.

The principle on which the device depends for its operation is, as its name indicates, the same as that on which the glow-discharge oscillators operate. This basic principle is that in any glow-discharge tube or device the ignition or starting potential is of higher value than the extinction or stopping potential.

It is well to state here that any glow-discharge device, because of that characteristic, is suitable for use as an oscillator of this type. Naturally, there are devices which are more suitable for that use than others, particularly regarding the stability

of the generated oscillations. The writer has built oscillators of this kind with a variety of devices which, apparently, were not suited for that use, as, for example: the 874 voltage regulator tube, the B-H full-wave rectifier, the B-R half-wave rectifier used in automobile radio B power supply, the 6-10 ampere trickle charger bulb, and even a spark-gap between carbon electrodes in air. Devices such as the grid-glow tube, the thyatron, the cold-cathode-day tubes, the Geissler tubes, mercury-vapor rectifiers, the photo-glow tube, etcetera, may be used in glow-discharge oscillators and, of course, in the new device discussed in this paper. The mentioned characteristic is common to all glow-discharge devices, from the familiar spark-gap to the multiple-electrode glow-tubes.

The glow-discharge oscillator is a circuit arrangement whereby a condenser is made alternately and automatically to charge and discharge through either a glow-tube or an impedance, which we will call the control impedance, although it is usually a pure resistance. Sometimes there is a series impedance in the tube's branch of the circuit, such as the protective resistor included within the bases of the common neon glow lamps, but this series impedance is not essential for the operation of the oscillator.

### Critical Factors

The critical factors which affect the operation of a glow-discharge oscillator are:

- The electromotive force of the source of current.
- The ignition and extinction potentials of the glow-tube.
- The maintenance current of the glow-discharge.

(d) The cathode-fall of potential in the glow-tube.

(e) The capacitance value of the control condenser.

(f) The nature and value of the control impedance.

(g) The nature and value of the series impedance.

Of these factors, some are controllable while others are typical of the glow-tube used. In the event that a thermionic glow-tube, such as a mercury-vapor rectifier, or a grid-controlled cold-cathode tube, such as the grid-glow-tube, is used, the characteristics of the tube are partially under the control of the operator; but if a gridless cold-cathode tube, such as a neon lamp, were used, the operator cannot control to an appreciable degree the constants of the tube.

### Conditions of Oscillation

The conditions of oscillation, deduced from the mathematical treatment of the phenomena involved, and borne out by experiment, may be summarized in the following general manner: (1) The electromotive force of the source of current must be higher than the ignition potential of the tube; and (2) The maximum value of the current through the control impedance must be lower than the maintenance current of the glow-discharge.

In consequence, there is a minimum critical value for the control impedance; also, if a series impedance is used with the tube, there is a maximum critical value for said series impedance, for each value of the control impedance. Values of the control impedance lower than the minimum critical value, and values of the series impedance greater than the corresponding maximum critical values, will make the period of oscillation of indefinitely large duration and the glow-discharge will be maintained.

The control impedance is usually a pure resistance, but inductances and capacitances could also be used, provided that there is a d.c. conductive path through the combination, and that the values of the latter are so proportioned as to limit the current to a value lower than the maintenance current of the glow-discharge. The series impedance, if used, may also contain inductance and capacitance values, but it must provide, as in the previous case, a d.c. conductive path for the current.

### Basis of Operation

Since the operation of these oscillators rests upon the alternate charging and discharging of the control condenser through impedances, the generated electrical oscillations consist of two transients, whose sequence constitutes one cycle. Usually, unless adjustments are made in the circuit constants, one of said transients is of much shorter duration than the other, and the wave-form of the oscillations, besides being peaked, is unsymmetrical, having a shape commonly known as a "saw-tooth" wave.

The stability of the oscillator depends principally upon the type of glow-tube used. The nature of the gas in the tube and its pressure; the nature, preparation and arrangement of the electrodes; space-charge effects; temperature variations; and variable stray electrostatic fields about the glow-tube, are the main factors which affect the stability of this type of oscillators.

The frequency of oscillation is nearly proportional to the product of the value of the mean current through the control impedance and the reciprocal of the capacitance value of the control condenser. Since the elements of the tube and the connections of the circuit have capacitance, it is possible, as the writer has done, to use that capacitance value instead of the external condenser and still have oscillations. It is difficult to conceive of a simpler type of electrical oscillator.

### The New Apparatus

Now that the critical factors and conditions of oscillation of this type of oscillators

have been reviewed, we will proceed with a description of the new apparatus.

Since the frequency of oscillation is a function of the values of the control condenser and of the control impedance, it follows that by changing either, the frequency will be varied. If the control impedance is a pure resistance, as is the usual arrangement, the frequency will approximately vary in inverse proportion to the value of said resistance.

If we substitute for the usual control impedance, a photo-electric cell, we will obtain what the writer calls a "photo-electric glow-discharge oscillator." This simple substitution has, in fact, produced a new device, for the impedance of the photo-electric cell, which acts now as the control impedance of the oscillator, is a function of the radiant energy incident on this cell and, in consequence, the frequency of oscillation will be a function of the radiation.

### Variety of Choice

The device, therefore, will produce electrical oscillations of constant amplitude (usually so), of the "saw-tooth" wave-form and of a frequency determined by the radiation acting on the photo-electric cell.

Whereas in the usual type of glow-discharge oscillators there is a minimum critical value for the control impedance, in the new device there is a maximum critical value of the controlling radiation. If this value is exceeded, the oscillations cease and the glow-discharge is maintained in the tube.

Any of the various types of photo-electric cells may be used in the device, such as photo-emissive cells like the caesium-oxide emitter, photo-conductive cells like the selenium bridge, or photo-voltaic cells like the cuprous-oxide or "sandwich" cells.

The glow-discharge tube used is a  $\frac{3}{4}$ -watt, S  $4\frac{1}{2}$ -bulb, neon glow lamp (manufactured by the General Electric Vapor Lamp Co.), and without protective resistor included within its base. The ignition potential of this particular tube is of 79.9 volts, the extinction potential is 56.4 volts and the maintenance current of the glow-discharge is of approximately 0.04 milliampere.

The photo-electric cell used is a Visitron, Type 75A, gas-filled, cesium-oxide emitter (manufactured by the G. M. Laboratories, Inc.).

### Nearly Linear

The performance of the device is very good, as shown by the frequency-radiation characteristic given in Fig. 1. The action of the oscillator is almost linear, as indicated by the nearly constant slope of the characteristic frequency-radiation curve. This was to be expected, since the current through the photo-cell is directly proportional to the radiation, and the frequency is proportional to the current. The critical maximum of radiation for the device was found to be of approximately 60 foot-candles, but the oscillations are not stable at radiation values greater than about 45 foot-candles.

If a photo-voltaic cell were used instead of a photo-emissive one, the frequency-radiation characteristic would also be linear. But if a photo-conductive cell were used, the characteristic would be parabolic, which makes the device very sensitive at low radiation values, a valuable property in several applications to be described later on. The sensitivity of the device described is, up to 1,000 cycles per second, of 2,710 cycles per second per lumen.

### Curve Irregularity

With the particular device described, the frequency-radiation characteristic bends upwards and to the left for radiation values between 45 and the limiting 60 foot-candles, showing a maximum frequency of 1,400 cycles per second at approximately 47 foot-candles. This bend of the curve is due to the presence of the headphones, which act as a series impedance of about 2,350 ohms resistance and 0.6 henry inductance.

This irregularity of the characteristic

curve is brought out in a striking manner if an inductor of larger value is placed in series with the neon lamp and the headphones, thereby increasing the series impedance. The frequency-radiation characteristic for the new arrangement becomes irregular, showing a series of maxima and minima frequency values as the illumination is uniformly increased from zero. These maxima and minima give to the curve an appearance somewhat similar to the steps of a stair, the changes from maxima to minima being usually sudden, while the changes from minima to maxima are usually linear.

The maxima and minima indicate those oscillatory states where certain harmonics of the oscillations correspond to the resonance frequency of the series circuit formed by the control condenser and the series impedance. That this is so is proven by the fact that the maxima and minima are harmonically related to said resonance frequency and to each other.

Therefore, the device is adaptable, not only to those purposes where it is desired that a change in radiation be accompanied by a similarly directed change in frequency, but also to those cases where a change in radiation should produce an oppositely directed change in frequency.

If it is desired that there should be oscillation when the radiation is zero, a resistance of from 3 to 25 megohms may be connected in parallel with the photo-electric cell. This arrangement lowers the maximum limiting value of radiation, but it points out the interesting fact that the slope of the straight portion of the characteristic curve is approximately the same as that of the curve taken without shunt resistor (Fig. 1).

### Amplification

Although in the experimental apparatus described the oscillations are fairly audible by means of the headphones, further amplification might be required in particular cases. This may be easily accomplished by means of thermionic amplifiers.

The voltage fluctuations in the oscillator are nearly independent of the frequency of oscillation, since the ignition and extinction potentials of the neon lamps are practically constant quantities. These voltage fluctuations are usually of relatively large value: in the device described, the voltage across the condenser oscillates between 56.4 and 80 volts, and the voltage across the photo-electric cell oscillates between 10 and 33.6 volts.

The input to the grid circuit of the thermionic amplifier may be obtained from a variety of places in the oscillator: across the photo-cell, across the glow-tube, across part or all of the series impedance if any is used, or across the condenser. Since the voltage oscillations are of relatively large value, care must be had in the selection of the amplifier. In the case considered, tubes such as the 71A and 45 are appropriate for purposes of amplification.

The fundamental frequency of this type of oscillator extends from the extremely low frequencies to the lower radio-frequencies. Since the wave-form is of the "saw-tooth" type, the oscillations are very rich in harmonics as shown by the Fourier analysis. Therefore, it is possible to detect and amplify the upper harmonics and thus reach into the radio-frequency range. The amplitude of any harmonic of a "saw-tooth" wave is approximately in inverse proportion to a power of its order of value between one and two, the exact value of that exponent depending upon the wave-form. The upper limit of the fundamental frequency is principally determined by the characteristics of the glow-discharge tube used, which limit both the minimum values of the control impedance and the condenser. With the usual types of glow-tubes the upper limit lies around 100 kilocycles. The writer built an oscillator using a 6-10-ampere trickle charger bulb whose upper limit for the fundamental frequency was of approximately 80 kilocycles.

(Continued on next page)

(Continued from preceding page)

The photo-electric glow-discharge oscillator has multiple applications. One of the more interesting of these applications constitutes what he writer calls the "ommaphone," a device which permits the blind to read common print. Another application is to electro-musical instruments. Further applications include: photometry, colorimetry, relay work, talking motion pictures and television.

### The Ommaphone

This device, as its name implies (from Gr. "omma," eye, and "phone," sound), is a "sonorific eye," i.e., it provides vision through sound. It is particularly adapted to the perception of written or printed characters by the blind.

The principle of the device is as follows: a thin line of light is projected upon the characters to be read and moved over them by hand. The light reflected from said characters is collected by the photo-cell of a photo-electric glow-discharge oscillator and converted thereby into sound vibrations in a sound reproducer.

Since the characters have different forms, the displacement of the line of light over them will vary the illumination on the photo-cell and, in consequence, the sound produced will vary in proportion to the forms of the characters. The whiter or darker the spot where the line of light incides, the greater or lesser will be the illumination on the photo-cell and the higher or lower the tone of the note emanating from the sound reproducer.

### How It Works

In that manner, for each letter or character, there is a definite and typical variation of the pitch of the note produced. With a little practice it is possible to associate those variations with the corresponding letters or characters and thereby be able to differentiate between the latter and, hence, read by means of the ommaphone.

The line of light is projected so that its length is perpendicular or nearly so, to the written or printed lines, and it is moved by hand over the characters in the same direction as the written or printed lines are to be read, from left to right in the case of the principal languages.

With an experimental ommaphone, the variations in pitch are not large: the frequencies are of 350 cycles per second for the white part of the paper, and 330 cycles per second for the darkest part of a letter, like the vertical bar of the E. This variation is only of a semi-tone and being so small, makes it difficult to differentiate between similarly sounding letters like the B, D, P and R.

The photo-electric cell used is a cesium-oxide emitter, gas-filled (Visitron, type 58AWB), its cathode being centrally perforated by a  $\frac{3}{8}$  inch by  $\frac{1}{4}$  inch aperture. The neon lamp is of the same type as the one used in the device of Fig. 2. The light source is a G. E. galvanometer lamp with straight wire filament, 3.5-4-volt, 0.5-ampere rating.

### Stray Capacities Used

The oscillator has no external condenser. The internal distributed capacities of the connections and of the neon lamp act as the control condenser. Because of the small currents and high resistances involved, there is some body capacity effect in this particular device, specially when the movable box is touched by the hand. Nevertheless, the experimental ommaphone shows that the device is practical and that it gives good performance. Several improvements are readily apparent.

In order to increase the sensitivity of the ommaphone, a photo-conductive cell could be substituted for the photo-emissive one. In fact, it was mentioned that a photo-electric glow-discharge oscillator involving a photo-conductive cell has a parabolic frequency-radiation characteristic, whose slope is very small at low radiation values. This property is most desirable in the case of the om-

maphone, since it not only would give greater sensitivity to the device, but would also permit the reduction of the necessary light flux.

The batteries could be substituted by a suitable B eliminator. Since, in all probability, the light source would then be operated by alternating current, a photo-conductive cell should be used instead of a photo-emissive one. In fact, the latter would follow the light flux variations caused by the alternating current supply, and the oscillator would produce a modulated tone. The photo-conductive cell, on the other hand, usually has so much lag that the light flux variations will have little influence in the oscillator's output.

### Other Advantages

Photo-conductive cells have other advantages over the photo-emitters, regarding their use in the ommaphone. Such advantages are, for example, their smaller size, their greater strength and their lower cost. If the ommaphone is to be made a portable device, battery operation is necessary. Simplification of this kind of operation can be secured by the use of thermionic glow-discharge tubes which can be built so as to have a very low ignition or starting potential and, in that manner, the size and cost of the necessary batteries would be considerably reduced.

An appropriate guiding device for the movable box could be incorporated, so that the operator could easily and accurately follow the written or printed lines. The rollers of the experimental ommaphone (see Fig. 5) serve this purpose to a certain extent. Other improvements might be the reduction in size of the movable box, the modification of the light projections means, etc.

### Electric Music

The photo-electric glow-discharge oscillator, operating at audio-frequencies, is well adapted for use in electro-musical instruments. The tonal variations are produced by varying the radiation acting on the photo-electric cell of the device. Many practical arrangements are possible for this application.

The variations of illumination on the photo-cell are secured, in this particular instrument, by means of a shutter-like affair which is operated by hand through a lever. The shutter gradually opens or closes a small aperture through which the radiation from a light-source passes to incide on the photo-cell.

A single stage of amplification, provided by a 45 tube, is required to bring the generated oscillations to a good sound level.

A manually operated switch-key permits "muting" of the notes as desired by the player. The proper illumination is adjusted by means of a rheostat, the knob of which is shown on the left side of the box. This rheostat varies the current through the light-source and thus provides means for tuning the instrument.

Since a photo-emissive cell (Visitron 75A, gas-filled) is used, it is necessary to operate the light-source by direct current, because alternating current operation of the light-source would introduce modulation in the oscillator's output, as was mentioned in the case of the ommaphone. If a photo-conductive cell were used instead, no such precaution would be necessary, due to the usual electrical inertia of this type of photo-cells.

The neon tube is a 2-watt, S-14 bulb, neon glow lamp (manufactured by the General Electric Vapor Lamp Co.) and without protective resistor. The light-source consists of a 2.5 volts, 0.3-ampere, type 14, Mazda lamp, and a small hemispherical metallic reflector.

### Agreeable Sound

The instrument possesses a non-disagreeable timbre. Its musical range is adjusted to cover two octaves, nearly the same range of the bass voice. By increasing the current through the light-source, this range can be increased to a considerable degree, but the

intervals on the arc become too crowded for facility of operation.

The instrument could be improved by providing means for adjusting the volume of the generated tones. As it is, there is only one volume level. Another improvement would consist in the alternating current operation of the light-source. The first improvement may be attained by intercalating two or more "muting" keys in the loud speaker circuit, one key for each desired volume level. The second improvement may be accomplished, as previously explained, by the use of a photo-conductive cell.

Other improvements could be made regarding the quality of the sound generated by the instrument. Suitable audio-frequency filters or additional photo-electric glow-discharge oscillators may be used so as to enhance or suppress certain harmonics and, thereby, change the timbre of the sounds.

Many other electro-musical instruments can be devised along the same lines of the experimental form described.

### Photometry, Colorimetry, Relay

The photo-electric glow-discharge oscillator provides a means of measuring radiation values. Since the photo-electric cell, like a human eye, is a discriminative device, the oscillator will provide measurements, not only of quantity values, but also of quality values of the radiation incident on the photo-cell.

The oscillator converts radiation values into frequency values. It is only necessary, therefore, to provide means for measuring the latter. Several such means are available.

A sensitive current meter, if placed in series with the glow-tube, will show an increasing deflection for increasing illumination on the photo-electric cell. This is due to the fact that the time of discharge of the control condenser across the glow-tube and the meter in series, decreases at a slower rate than does the control impedance. Therefore, the mean current through the glow-tube and the meter will increase as the frequency increases. This arrangement is not very sensitive.

If the generated frequencies are in the audio-frequency range, they may be measured by comparison with suitable audio-frequency primary or secondary standards, such as provided by a sonometer or a properly tuned musical instrument.

Another means of measuring the generated frequencies is by impressing the oscillator's output on the grid circuit of a thermionic amplifier, the output circuit of which contains an electrical filter and a current meter. This arrangement can be made very sensitive at certain radiation levels, by adjusting the filter constants.

### Graphic Possibilities

For the low frequencies an electromagnetic relay may be used in series with the glow-tube, the relay closing or opening at every cycle under the influence of the discharge of the control condenser across the tube and the relay coil in series. The writer built a device of this kind, using a BR half-wave rectifier tube and a 4 mfd. control condenser. The device was capable of operating an electromagnet of only a few hundred turns, up to a frequency of about 10 cycles per second. The relay can be arranged so as to make a graphic record of the number of discharges. This device is simpler than the Rentschler ultraviolet frequency indicator used for measuring therapeutic radiations.

For intermediate and lower radio-frequencies, a wave-meter may be used to measure the frequency of oscillation.

Several applications of the oscillator to relay work may be devised. One interesting application of this kind is as follows: the oscillator's output is amplified by means of a suitable thermionic amplifier, the output of which is impressed upon a series circuit formed by an electromagnetic relay and a condenser. The relay is operable by alternating current. When a given level of illumination acts on the photo-cell, the gen-



## Centeno's Television Method

erated frequency will coincide with the resonant frequency of the series circuit and the maximum current will flow through this circuit. If this maximum current is adjusted so as to be equal to the minimum current that will operate the relay, the latter will open or close only when that level of illumination acts on the photo-cell, and at no other time.

### Applied to a Star

Another interesting relay application would be in recording the passage of a star over a given meridian, and thus determining the exact time. Nowadays, this is accomplished in the astronomical observatories by means of a telescope, a photo-electric cell and an auxiliary device which produces a musical tone when the light from the star incides on the photo-cell. As soon as this light is interrupted by the hair line of the telescope, the musical note ceases. A photo-electric glow-discharge oscillator may be substituted for the photo-cell and the auxiliary device. Under the influence of the light from the star, the tone generated by the oscillator will be higher than when the light is interrupted by the hair line in the collimator's slit of the telescope. The difference in tone secured during the passage of the star would, then, give a means of recording the exact time of the passage.

If modulated radiation incides on the photo-emissive cell of a photo-electric glow-discharge oscillator, the output of the latter will be of approximately constant amplitude, but of a frequency which varies in exact accordance with the instantaneous values of the incident radiation. In other words, the oscillator's output will be frequency-modulated. It is necessary, to avoid distortion, that the minimum allowable frequency be greater than the maximum frequency of modulation.

A frequency-modulated wave of constant amplitude, if applied on the input to a filter circuit, will produce a wave which is modulated both in frequency and in amplitude. If this wave is detected in the usual manner, the amplitude modulation of the same can be made perceptible after detection, either to the ear through a sound reproducer, or to the eye by means of a glow-lamp or other instantaneously responsive light-source.

Therefore, the photo-electric glow-discharge oscillator is suitable for use in talking motion pictures and in television. The principal advantage of those applications of the device lies in the considerable simplification of the problem of amplifying the corresponding signals. In fact, the voltage amplitude of the oscillations generated by an oscillator to this kind is relatively very large, thereby requiring little additional amplification so as to bring those oscillations to an usable level. A single stage of amplification is generally sufficient.

### Frequency Range

In sound movies, the necessary frequency range of the signals extends from 60 to 5,000 cycles per second or hertz. We shall consider separately the cases of regular and noiseless types of sound recording, both of the variable area and of the variable density types. In the first case we may assume, as an example of this application, that the oscillator is adjusted to generate a frequency of 30,000 hertz when the photo-cell is under the mean light flux that passes through the sound track, and its constants so chosen that under the maximum and minimum illumination values, the frequencies are of 40,000 and 20,000 hertz, respectively. The 30,000 cycle wave would then serve the purposes of a carrier. If a sinusoidal light flux modulation is impressed on the photo-cell, the generated frequencies would oscillate in a sinusoidal manner about the 30,000 hertz wave as a mean value.

In the case of the noiseless types of sound recording, the oscillator should be adjusted to a frequency under minimum illumination of, let us assume, 30,000 hertz. Under maximum illumination the frequency would increase to, let us assume, 40,000 hertz. If a light modulation corresponding to the average volume of sound is impressed on the photo-cell, the carrier frequency would be of 32,500 hertz. For light modulations corresponding to low or high sound volumes, the carrier frequencies would be lesser or greater than 32,500 hertz, respectively.

### Constant Amplitude

In both cases, the amplitude of the voltage oscillations will be approximately constant. After filtering and detecting, they will still have sufficient amplitude to require only a single stage of amplification. The filtering and detecting may be accomplished in a pre-amplifying stage.

In television, the necessary frequency range is considerably greater than in sound movies. For a 500-line square picture and a frame frequency of 24 hertz, the frequency band required extends from 24 to 300,000 hertz. Therefore, if the photo-electric glow-discharge oscillator is to be adapted to television work, it must operate in the radio-frequency range. This may be accomplished, as previously explained, by detecting and amplifying the upper harmonics of the generated oscillations. Although the voltage amplitude of those harmonics is smaller than the voltage amplitude of the fundamental frequency of a "saw-tooth" wave, it is still much greater than the voltage output obtained from the standard television pickup systems.

The low radiation intensities present in television scanning do not constitute a handicap in this possible application of the device, for there are means whereby the photo-electric glow-discharge oscillator may be made very sensitive at low radiation values.

### Tiny Values Magnified

For instance, it has been mentioned that if an inductive series impedance is used in the oscillator, there are sudden frequency variations for small radiation changes, at several points on the frequency-radiation characteristic. Therefore, by operating the oscillator at one of those points, very small variations in illumination may be considerably magnified.

In consequence, the device can be used in television transmission with the advantage that it simplifies to a large degree the amplification problem of the minute television signals.

## Police Radio Started Twelve Years Ago

The first installation in the United States of police radio broadcasting equipment was in Harrisburg in 1921. The equipment consisted of a 500-watt radio telephone transmitter designed by Westinghouse and manufactured at the East Pittsburgh Westinghouse plant. This transmitter was designed for point to point radio telephone service rather than for traveling automobile as is now common with police radio installations.

The installation at Harrisburg was for the Pennsylvania State Police and the equipment was donated by the Westinghouse Co. for the experiment.

New York had a police radio system as far back as 1916 (KUVS). However, this station was used only for such patrol boat service in New York harbor. The city of Detroit also had a radio station installed for police service in 1921; however, it was later abandoned and activity was not resumed until 1929.

## VOICES ALOFT 11 MILES HEARD VERY CLEARLY

Radio engineers of the National Broadcasting Company are preparing to check their data on radio's latest achievement, the transmission of the human voice from the stratosphere, attained during the ascent of Lieutenant Commander T. G. W. Settle, U. S. N., and Major Chester L. Fordney, U. S. Marine Corps, to an approximate height of 59,000 feet.

Never before had the human voice been heard from an altitude above the atmospheric levels, and yet so clearly were the voices of Commander Settle and Major Fordney heard during the seven broadcasts relayed to the public over NBC network facilities that listeners found it hard to believe that the broadcasts were the first attempted from such a height. By means of short-wave transmitters, the National Broadcasting Company was in almost constant communication with the balloonists from the moment they began their ascent in Akron, Ohio, at 8:29 a. m., CST., until shortly before they landed near Bridgeton, N. J., at 4:50 p. m., CST.

### First from U. S. Soil

The ascent, sponsored by the National Broadcasting Company and the Chicago "Daily News," was the first of its kind ever made from American soil, and will be recognized, it is believed, as having set the official world's record for altitude.

Even more remarkable than the fact of radio communication itself, from the view of the layman, is the fact that the broadcasts from the gondola of the balloon were made on a five-watt transmitter, consuming only one-fifth of the power used by an ordinary twenty-five watt electric light bulb. The balloon was in touch with NBC short-wave stations at Chicago, New York, Washington and Akron. The frequency used was 15,760 kc, the frequency decided upon by engineers as most suitable to the purpose.

Both reception and transmission to and from the balloon were pronounced as entirely satisfactory by Howard Luttgens, chief engineer of the central NBC division, in charge of radio arrangements for the ascent. The only unforeseen circumstance was that volume in the balloon transmitter had to be reduced more than is usual in a ground transmitter. This and other phenomena will be checked upon by NBC engineers immediately.

### Clear Cosmic Ray Photos

Radio communication with the balloon was lost shortly before the landing when Commander Settle was compelled to toss overboard his batteries in order to decrease the speed of descent. It was only then that the radio engineers became concerned about the two balloonists.

Niles Trammell, vice-president of the National Broadcasting Company, Frank J. Knox, publisher of the Chicago "Daily News," and Admiral Ernest K. King, chief of the naval bureau of aeronautics, were heard at various times over NBC facilities, in conversation with Commander Settle and Major Fordney. At other times the balloonists were supplied by radio with valuable weather data and information on their location.

The moving picture exposure of cosmic rays was sent to the University of California, where it was stated the pictures were much clearer than those obtained previously by others. There were eight feet of useful film.

# Radio University

**A QUESTION and Answer Department. Only questions from Radio University members are answered. Such membership is obtained by sending subscription order direct to RADIO WORLD for one year (52 issues) at \$6 without any other premium.**

RADIO WORLD, 145 WEST 45th STREET, NEW YORK, N. Y.

## Cure for R-F Oscillation

AGAIN SOME SQUEALING. This time I have traced it to the signal level of a superheterodyne. I know this, because there is no squealing at frequencies below 1,300 kc, only from 1,300 kc up to 1,600 kc (the dial end). Besides, touching the r-f tube grid with wet finger gives the characteristic plop of an oscillating tube. Remedy, please!—J. E. D.

We take your word for it that the squealing is just as you diagnose it, r-f level trouble, nevertheless we suggest that as a first precaution you verify the fact that the oscillator parallel trimmer is precisely set for greatest response at 1,450 kc, and that the oscillator then is at a frequency higher than the signal, not lower, for maximum deflection would be obtained also at this lower frequency setting. With that precaution taken, the remedy may be applied as follows: Take a rheostat or potentiometer of around 25,000 ohms resistance, or if you haven't anything higher than 10,000 ohms, use that. The instrument is used as a rheostat and connected across the primary of the antenna coupler. Put maximum resistance in circuit this way. Then turn the receiver to the highest frequency to which it responds, turn up the volume control all the way, let the set oscillate, and turn the rheostat knob until the oscillation completely disappears. Remove the rheostat, noting the terminals you used, and measure the resistance that was necessary to correct squealing. Then solder a fixed resistor of approximately that resistance across the primary of the antenna coupler and leave it there. This method is bound to work, unless possibly you have two stages of r-f ahead of the modulator, when as a rare possibility the second r-f stage would be oscillating, when the remedy could be applied there. Also with two r-f stages it is faintly possible that both stages would be oscillating, and that might require introduction of the remedy in both circuits, although usually the antenna coil remedy is sufficient for one or two stages of i-f, and no matter which is oscillating, because of the reflected effect of the resistance, or the reduction of the harmful gain that caused the feedback.

## Loss of Sensitivity

MY SUPERHETERODYNE formerly tuned to well above 1,500 kc. For the past two weeks it has not reached lower than 1,400 kc. Also the sensitivity in the high-frequency region has dropped away off, although it holds up all right at the low frequencies.—O. W. D.

The trimming condenser across the oscillator has been closed in too far, possibly as the result of being struck an accidental blow. Examine this condenser. Release the moving plate until there is maximum response at 1,450 kc, and then the formerly acceptable reception conditions in the high-frequency region will be restored.

## Access to Voice Coil

TO USE an output meter (regular a-c meter) to measure the voltage across the voice coil, because there is no d-c there, how can I make the connections, as the voice coil leads are not brought out?—J. S. W.

You can attach test leads to the meter, the

free ends having rubber-insulated spring clips. These clips can be inserted between the staves of the speaker frame to reach the voice coil terminals, and the measurement thus made. In some exceptional cases it is necessary to scrape off a little of the insulation from the connecting wire from voice coil to terminals in the speaker because the conductive terminals are not accessible.

## Hum Remedies

IS THE 2A5 to be preferred to the 47? I am about to build a set with either as output and would like advice. Also, would a filter of two 8 mfd. condensers, one on each end of the B choke, be sufficient?—K. D.

The 2A5 is generally preferable, for although it has about the same characteristics as the 47, it is a heater type tube, and hum is therefore less. The two 8 mfd. condensers and choke usually are not quite sufficient, and it is preferable for considerable reduction in hum to use 16 mfd. next to the rectifier (one side of the 16 mfd. to filament of rectifier tube). Another assistance in reducing hum is to try reversing the connections to primary of the output transformer, as sometimes there is considerably less hum one way than the other. This can not be done if B plus for the primary is permanently tied to the choke inside the speaker, but only in rare instances does this permanence prevail, and besides when the work is done at the factory the connection is usually in the more favorable way. Another help is to put a resistor of 0.1 meg. in series with the grid resistor in the pentode output circuit, and put a condenser of 0.1 mfd. or higher capacity from the return of the load resistor proper to ground.

## How Many I-F Stages?

WHICH IS PREFERABLE in a set using diode second detector, two stages of i-f or one stage of i.f.?—P. E.

Two stages are preferable, because the selectivity is considerably higher. With only one stage the selectivity might not be good enough with a diode, although it would be with a triode, quadrole or pentode second detector. The reason is that the diode load resistor is in series with a tuned circuit and its impedance to the intermediate frequency can not be reduced sufficiently by any capacity across this resistor, as a large enough capacity would attenuate the high audio frequencies too much.

## Extreme Remedy for I-F Squeals

WELL, I AM HERE with a question about oscillation in an intermediate amplifier. I tried the usual remedies, including those you recommend, also some unusual ones you mention occasionally, but no go. The set has automatic volume control. Does feedback through the resistors in the a.v.c. legs of the grid returns cause this back coupling?—I. D.

This may be a cause. However, we have a remedy for the extraordinary condition you report, although it is one to be applied only in extreme cases. Omit entirely the condenser from grid return of a tube governed by a.v.c., and simply connect the un-bypassed resistor to the return of the i-f coil feeding the detector, which is the high

side of the diode load resistor. And if this does not completely do the trick, similarly leave off the condenser from the other resistor in the a.v.c. circuit (assuming you have two i-f tubes, both controlled).

## Resistance of An Antenna

SHOULD the radiation resistance of an antenna be high or low when it is used for transmitting signals? Should it be high or low when it is used for reception? What is the difference between the radiation resistance of the antenna and the plain resistance?—W. T.

The radiation resistance should be as high as possible if it is to radiate well, for the radiation resistance is a measure of the capability of the antenna to radiate. If the radiation resistance is high when the antenna is used for transmission it is also an effective collector of energy radiated from some other antenna. Any device that is a good radiator of light, heat or radio waves is also a good absorber. As was stated above, the radiation resistance is a measure of the energy radiated from the antenna. The resistance of the antenna is a measure of the total energy lost in the antenna, whether the loss is caused by radiation or by losses in the wire or in dielectrics around the antenna. Energy lost by radiation should not really be called a loss for the sole purpose of the antenna of a transmitting station is to radiate energy.

## Crystal Oscillator Constancy

WHAT ARE the main causes for frequency variation in a crystal oscillator? To what constancy can such an oscillator be adjusted?—F. E. W.

Changes in the operating voltages on the tube will change the frequency by a small amount. Changes of tubes will also change the frequency slightly because this changes the grid and plate resistances as well as the grid and plate capacities. Vibration is a cause for small changes in frequency. Perhaps the greatest source of change is the temperature fluctuations which affect the properties of the crystal itself. To guard against variations of frequency with temperature the crystal is put inside a constant temperature chamber where the temperature is held constant within 0.01 degree Centigrade. Crystal oscillators have been constructed in which the variation from all causes was not more than one part in 100,000,000. It is not extremely difficult to get a constancy of one part in one million. A transmitting station is allowed a deviation of 50 cycles plus or minus. This is not a very serious restriction now for if the carrier is one million cycles per second the constancy of the oscillator need be only five parts in 100,000. It will be noticed that the small stations operating on frequencies around 1,500 kc have more difficulty keeping on their waves than the larger stations operating near the 550 kc limit. In fact, the demands on the small stations is nearly three times as great. Even so, the demand is not very great when crystal control is used.

## Change of Inductance with Frequency

WHY DOES the inductance of a coil change with changes in frequency? Can the amount of change be computed by known formulas?—W. R. T.

The inductance of a coil is usually computed on the basis of a current sheet. That is, the wire is infinitely thin and there is no separation between adjacent turns. Moreover, no allowance is made for the pitch of the helix. When the wire is infinitely thin there can be no change in the distribution of the current through the wire, and there would be no change in the inductance with frequency. An actual coil is usually wound with round wire of considerable diameter and there is an appreciable separation between adjacent turns. Formulas are available for computing corrections due to spacing and roundness of the wire. These corrections apply to low frequency induc-

tance. As the frequency increases the current distribution in the turns changes, for the higher the frequency the nearer the surface will the current flow. This changes the inductance. There are formulas available for making corrections for this, too.

**Adjustments of Meter Shunts**

PLEASE give a formula by which to determine the shunts required on a milliammeter to extend the range of the instrument. I know how to do it experimentally, but I should like to have a formula by which I could get the values to work toward.—W. R. Y.

If the meter resistance is  $R_m$  and the shunt resistance is  $R_s$ , the formula is  $R_s = R_m / (I / I_m - 1)$  in which  $I$  is the maximum resistance you want to read and  $I_m$  is the maximum reading on the meter without the shunt. Thus if  $I_m$  is 1 milliamper and you want to extend the range to 10 milliamperes,  $R_s = R_m / 9$ . If you want to extend the range to 100 milliamperes  $R_s = R_m / 99$ . You must know the internal resistance of the meter before you can get the values of the shunts in any case.

**Inertia of Electrons**

IF ELECTRONS have a definite mass is there not a limit to the frequency at which they can oscillate back and forth in the space between the plate and the anode? If so, why is this not taken into account in designing oscillators?—R. L.

Yes, the inertia of the electrons has an effect on the oscillation, and the reason it is not taken into account is that it is entirely negligible for any frequency that has yet been used extensively. In ultra-high frequency oscillators like the Barkhausen-Kurz it is taken into account and is used for tuning the circuits. The frequency changes with the applied voltages.

**Motorboating in Receiver**

WHEN the volume in my set is turned up the circuit starts to stutter. I have applied all the remedies for motorboating that I can think of but nothing seems to help. Can you suggest anything else to do?—R. A.

Remedies for motorboating should not help in this case because it is not motorboating. It is undoubtedly due to blocking of a grid somewhere. Try lower grid leak in all the stages where there is a leak. This includes the audio amplifier. Look especially to the oscillator if you have one in the circuit, and also to the tubes connected to the automatic volume control, if you have one. It may possibly be that a grid is open at the ground end of the coil. Test this on both high and audio frequency amplifiers. Stuttering is often associated with the oscillator in a superheterodyne. If the grid leak is too high the grid accumulates a charge which stops oscillation. While the circuit is not oscillating this charge leaks off and permits the oscillator to function again. The charge builds up anew. This stopping and starting may occur at any rate from an occasional putter to a high rate, which is so rapid that it is above audibility.

**Class B without Power Driver**

IS it possible to have Class B amplification without the use of a power driver ahead of the power stage? If so, please explain how it can be done.—R. T. N.

A Class B amplifier is a push-pull amplifier in which the two tubes have been biased to the cut-off point or very nearly to the cut-off point. Hence to have a Class B amplifier it is only necessary to increase the bias on a push-pull stage. When this is done it is not necessary to have a power driver but only an ordinary Class A voltage amplifier ahead of the power stage. When the push-pull amplifier is to be operated without a power driver, tubes requiring a high bias must be used in the power stage, and not those especially designed for Class B, no bias, amplifiers. A complication arises

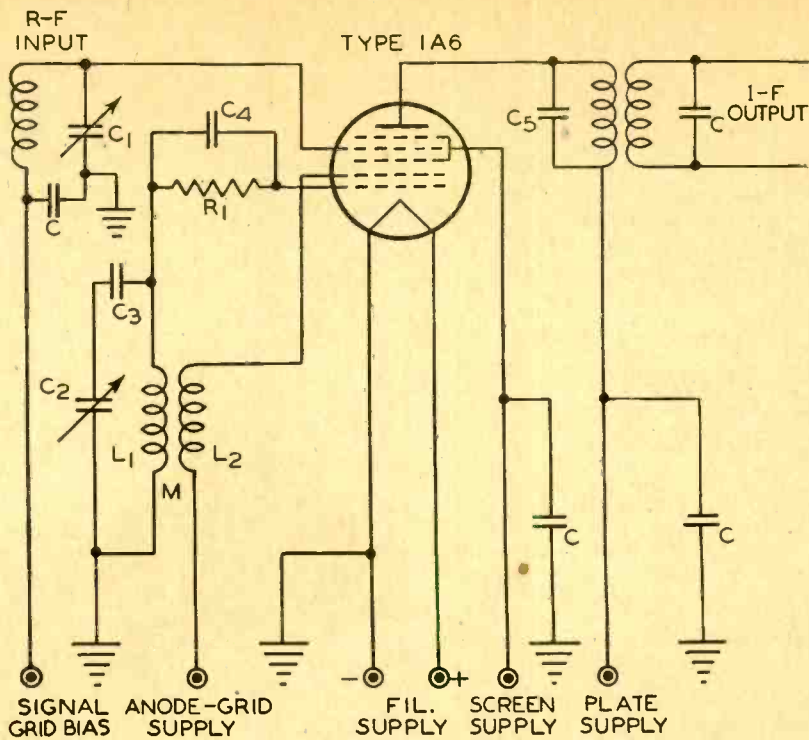

The battery-operated pentagrid converter tube, 1A6, used as mixer in a superheterodyne. This is a 2-volt filament type tube.

when the push-pull tubes are much over-biased, and that is the method of providing the bias. Self-bias will not work at all. The bias might be taken from a voltage drop in the negative lead of the power supply when the cathodes or filaments of the tubes are connected to the positive end of this resistance and the grid returns to the negative end. If this results in too much loss of voltage, the bias might be obtained from the field coil of the dynamic speaker provided this is placed in the negative lead. Another and better way is to build a small C supply into the circuit. This requires a small tube as rectifier and a transformer giving a secondary voltage of about 100 volts. It is easy to filter the output of this C supply. A pair of 45 tubes used as Class B with bias to the cut-off point should have a bias of about 100 volts. The same C supply could be used for biasing the other tubes in the receiver or amplifier.

**High Selectivity**

WHAT ARE the highest selectivities that can be obtained with a single coil and condenser, a quartz crystal, and a magnetostriction rod? I refer to the ratio of the inductive reactance to the effective resistance.—W. E. M.

A selectivity of 100 is quite high for a circuit consisting of a coil and condenser, but higher values may be obtained. If we have a coil of 250 microhenries and a condenser of 250 mmfd. and a resistance in the circuit of 4 ohms, we get a selectivity of 250. That is possible but not likely. Dye gives values on a crystal in which the effective inductance was 160 henries, the effective capacity 0.08 mmfd., and the effective resistance 1,500 ohms. This combination gives a selectivity of 29,800. A magnetostriction resonator is not far behind the crystal.

**1A6 Circuit**

IS IT ALL RIGHT to use an intermediate-frequency transformer with one circuit tuned in the succeeding grid circuit, and with untuned plate winding in the output of the 1A6? Please give me some idea of values of constants.—K.E.S.

The transformer may be used as you suggest, but it is somewhat preferable to have a higher capacity across the plate load than would thus result, to improve the bypassing of the higher frequencies. Therefore a small

condenser, around 50 mmfd., may be used for C5, where C at the r-f input is the regular tuning condenser of the intermediate (see diagram on this page). A more favorable method would be to use the tuned circuit in the plate position and leave the grid untuned, with no condenser across that winding. C as shown elsewhere than across the intermediate secondary is 0.1 mfd., C1 and C2 are ganged tuning condensers, C3 is the padding condenser, L1 is the oscillator tuned winding. C4 is 0.0002 mfd. and R1 is 50,000 ohms, the last-named being grid condenser and leak. The filament supply should be 2 volts across the tube terminals. If there is more voltage externally (3 or 6, for instance), drop the difference in a resistor. For C1 = 350 mmfd., the coil it tunes is 230 microhenries, attained by winding 127 turns of No. 32 enamel wire on 1" diameter tubing. For 465 kc intermediate, C3 would be adjustable, 350-450 mmfd., and L1 would be 126 microhenries, 85 turns of No. 28 enamel wire on 1" diameter tubing.

**Bringing Out Highs in Talkies**

WHY are talking pictures operated at 24 frames per second whereas the old type were operated at 16 frames per second? Does this have anything to do with the reproduction of the high frequencies?—F. G. W.

There is much less flicker in a picture when the frame frequency is 24 per second than when it is only 16 per second. However, the main reason for increasing the frame frequency, as you surmise, is to make it possible to bring out the high audio frequencies. Whether or not the high frequencies will be brought out depends on the width of the slit in relation to the number of feet of film that passes per second. The first thing to do is to reduce the width of the slit, in the direction of the length of the film, as much as possible. It is not practical to reduce it for various reasons to much less than 0.001 inch. When this is not enough, the next thing is to speed up the film so that more footage will pass the slit per second. That lengthens all the wavelengths on the film and makes the slit narrower in effect. If the upper limit of frequency response was 10,000 cycles at a frame speed of 16 per second, it would be 15,000 at 24 frames per second, assuming that the same length of frame were used in the two instances.

# The Review

## Questions and Answers Based on Articles Printed in Last Week's Issue

### Questions

1. In what field is most of the original work in radio now being done?
2. What is a balanced Colpitts oscillator?
3. Describe the treatment to be applied to an antenna coil (a) to increase the stability and sensitivity, (b) to increase the selectivity, decrease the sensitivity and permit use of a much longer antenna.
4. What is the average gain per stage, compared to the theoretical  $\mu$  of the tube, in a resistance-coupled voltage amplifier?
5. Why does a pentode tube lose bias and increase its plate current considerably on loud passages, when the grid leak is too high, while the higher the grid leak in a detector, the higher the negative bias and lower the plate current under the same signal conditions?
6. What is the object of a large bypass condenser across a resistor that biases a power tube?
7. Is it generally true that the quality to be obtained from a tuned-radio-frequency receiver may be expected to be better than that obtainable from the run of superheterodynes? If this is true, why?
8. In a tuned-radio-frequency receiver, to enable use of a diode detector, and still have a grounded condenser tuning the secondary looking into the detector, what method of coupling is used?
9. Assuming a d-c set, with 48's in push-pull output, what is the approximate power output, and how does this compare to the power output of the average a-c receiver?
10. Describe a suitable tone control.
11. Do *potential* and *voltage* mean exactly the same thing? If not, distinguish them.
12. What is meant by *ground wave*? Does it mean the wave that actually enters the ground? Did it ever mean that?
13. State one of the risks in a double relay, that is, where a program is sent from some location thousands of miles away, picked up by one station (first relay), then the re-transmitted wave picked up by another station (second relay), and finally the second station's re-transmission picked up by a broadcasting station for third transmission.
14. State what method is to be used by KYW in its proposed new location outside Philadelphia, where it is moving from Chicago, to prevent interference with New York stations on the channel (1,110 kc) 10 kc removed from KYW's 1,020 kc.
15. What is the maximum voltage that may be safely applied to 58 and equivalent tubes as r-f amplifiers, exceeding which imperils the tubes and also tends to introduce instability?
16. Why isn't padding practical for the higher frequencies of coverage of an all-wave receiver?

17. Describe briefly the method of using half the dial for higher frequencies and full condenser capacity for lower frequencies in an all-wave set.
18. Describe how the inductance is selected for tuning the radio-frequency level, how it is selected for tuning the oscillator, and by what method the padding capacity is ascertained, in a superheterodyne.
19. What is the effect of shielding on inductance and capacity?
20. Why are the overhead grid wires shielded in receivers using screen grid tubes?

### Answers

1. Most of the original work in radio is now being done in the field of ultra frequencies.
2. The balanced Colpitts is a tuned grid, tuned plate oscillator, called balanced because the B supply voltage is introduced at the voltage node on the inductance, that is, at the same potential as ground.
3. To increase the stability and sensitivity more antenna winding turns are put on the coupler, and to increase the selectivity and decrease the sensitivity turns are removed from the antenna primary.
4. The practical gain per stage, with usual constants, is about half the theoretical  $\mu$  of the tube.
5. The pentode tube loses bias because grid current begins to flow, and the grid is made positive both by the signal itself, which is the primary cause of grid current, and that current makes the grid more positive. The absence of a stopping condenser in the grid circuit itself causes the accumulation of negative electrons at a faster rate than discharge through the leak. The stopping condenser in the audio amplifier leads to the previous plate circuit, rather than being connected only in the grid circuit, hence the operation is diametrically different from that of a grid-leak detector, where the greater the amplitude of the signal (or oscillation the greater the negative bias resulting from the voltage drop in the leak.
6. The object of a large bypass condenser across a resistor that biases a single tube by the voltage drop caused by B current flowing through that resistor is to prevent degeneration or negative feedback.
7. In general, it is true that better quality is obtainable from a tuned-radio-frequency set, because of lower selectivity and absence of sources of interference due to heterodyning, although in a carefully-designed and well-balanced superheterodyne freedom from such interference can be achieved.
8. Since the rotor of the tuning condenser is grounded, and the high side of the load resistor to which it would have to be connected can not be grounded, the tuned secondary is returned to ground, and a stopping condenser is connected to the high side of

that coil, other side of stopping condenser to a large-inductance choke, so that the choke may be returned to one side of the diode load resistor.

9. The approximate power for push-pull output is 4 watts and this compares favorably with the output of the run of a-c receivers having a single output tube.

10. A suitable tone control would consist of a condenser in series with a variable resistor, the total circuit across the audio line. Values of 0.05 mfd. and 250,000 ohms would be suitable.

11. The potential difference is the work done in carrying a unit charge from one point to the other against the electrical forces. The potential difference can be expressed in horsepower, voltage or in some other term. When the potential difference is measured in volts then it is taken as a voltage difference. Hence potential and voltage are not the same.

12. The ground wave is that part of the total wave that is radiated close to the ground. Formerly ground wave meant the wave that actually entered the ground, but this is a rapidly dissipated component.

13. One of the risks of a double relay is that the dangers of fading are doubled.

14. KYW will use directional transmission to avoid interference with stations on an adjoining frequency.

15. 250 volts.

16. Because the percentage of difference between the signal-level frequency (station carrier) and the oscillator frequency is entirely too small.

17. In an all-wave receiver, say, 500 to 15 meters, the full condenser of, say, 0.00035 mfd. capacity may be used for lower frequencies, yielding 3-to-1 frequency ratio, for 500 to 1,500 kc, 1,500 to 4,500 kc and 4,500 to 13,500 kc, and about half the condenser capacity, from minimum up, for the higher frequencies, because then there will be a better spreadout for the higher frequencies, and, with modern condensers, straight frequency tuning over this portion.

18. The inductance for tuning the radio-frequency level is selected on the basis of the maximum capacity of the tuning condenser, plus the associated capacities in the circuit, so that a low enough frequency will be reached, the high-frequency end taking care of itself, because the capacity ratio is large enough. For the oscillator the inductance is selected for the high-frequency end, on the basis of the minimum capacity, while the padding condenser is adjusted for tracking to that inductance at some low frequency, to reduce the effective capacity, because the oscillator's frequency ratio must be less than the r-f frequency ratio. The padding capacity is ascertained from knowledge of the maximum capacity and the selected inductance, and the formula is

$$C_x = \frac{C_1 C_2}{C_1 - C_2}$$

where  $C_x$  is the unknown padding capacity,  $C_1$  is the maximum capacity and  $C_2$  is the effective capacity required in circuit when the unknown is included in circuit.

19. The effect of shielding is to increase the capacity and decrease the inductance.

20. These wires are shielded to prevent direct pickup by these leads and to prevent feedback.

## RADIO WORLD AS A CHRISTMAS GIFT

There are thousands of sons, nephews and young family friends throughout the country who would be happy to receive Radio World for the coming year as a Christmas gift. We suggest that you send us the name and address of some one you have in mind who is interested in radio, and let's send Radio World for the coming year with your compliments. We will send a note of acknowledgment to this young man; and the receipt of Radio World during the following 52 weeks will be a constant reminder of your pleasant interest. \$6 a year (52 issues).

Subscription Dept., Radio World, 145 West 45th St., New York, N. Y.

## Stations Now 585, or 149 Loss in 6 Years

Washington.

Following is the broadcasting station tabulation:

Stations on Air	
December, 1933	March, 1927
585	734

### WHOM TO MOVE IN N. Y.

WHOM, New York City, is to erect a new transmitting aerial in New Jersey and move its New York studios to Madison Square Garden.

# Station Sparks

By Alice Remsen

## ACTIVITIES IN NORTH AND SOUTH

Silver Dust gave its last evening program for this year on December 2d. It will come back the first week of January with a new series of programs, thrice weekly—a different show each Tuesday, Thursday and Saturday; orchestra and soloist; two orchestras are auditioning for it and I shall be able to tell you definitely next week which won out; the soloists have already been selected, a tenor, a baritone and a contralto. . . . Station WBT, Charlotte, N. C., Southern key station of the Columbia Broadcasting System, has been granted permission by the Federal Radio Commission to increase its power to 50,000 watts. WBT is the oldest broadcasting station in the South, having been on the air since December, 1921. It has progressed in power from 50 watts to its present super-power strength, now making it the only high-powered broadcasting station in the southeastern section of the United States. . . .

## FRED WARING SIGNED UP

Fred Waring has another commercial; Lum and Abner go off and Fred Waring takes over the Ford Dealers program. WABC, Sunday nights at 8:30. Guest artists will be used; this new series starts on February 4th; will be heard on more than sixty stations. . . . And so it is Irene Taylor who won the Camel contract and not either Mildred Bailey or Sylvia Froos, although the latter was supposed to have been signed up for six weeks; well, such is radio—now you have a contract and now you haven't; it's just a game, on the order of ping-pong; anyhow, Miss Taylor will be co-starred with Glen Gray's Casa Loma Orchestra and the Do-Re-Mi Girls, and by the time this reaches press her first show, on December 7th, will be over and done with; it is a twice-weekly program, each Tuesday and Thursday at 10:00 p. m. WABC and network of eighty stations; Miss Taylor hails from the Lone Star State and possesses a rich mezzo-soprano voice, which comes over the microphone particularly well. . . . Pedro de Cordoba, who has been radioing for a considerable time via WABC, will probably be heard on the New York speaking stage very soon, as he is now rehearsing with Rachel Crothers' new comedy "Talent."

## WHAT'S THE MYSTERY ABOUT IT?

Gertrude Niesen keeps her gloves on when she sings before the microphone in order to deaden the sound made when she slaps her hands together in hot songs; I keep mine on for an entirely different reason which I refuse to divulge. . . . If the rumor is true that Georgie Beatty is leaving the cast of the American Revue show, I, for one, will be desolated, for I think his "Broken Arms Hotel" series for pure, unadulterated and original comedy, one of the funniest on the air. . . . You can tell WABC stars by their hobbies: Guy Lombardo, speed boats; Freddie Rich, prize fights; David Ross, poetry; Howard Barlow, log cabin in Connecticut; Lulu McConnell, flying; Little Jack Little, golf; the Boswell Sisters, their fan photographs; Helen Morgan, tropical fish; Mark Warnow, hypnotism; Jane Froham, Siamese cats, and Willard Robison, weird harmonies. . . . Elder Solomon Lightfoot Michaux, the happy colored preacher, who sings and slaps his congregation to salvation via WABC; from his meeting house on the banks of the Potomac River, changes to an earlier schedule; he may now be heard each Saturday at 7:30 p. m. . . . Vera Van, the blonde and curly-

haired contralto, will be heard with Stoopnagle and Budd on their new series for Pontiac, each Wednesday and Saturday at 9:15 p. m. This is Vera's first commercial engagement. Jacques Renard's Orchestra will supply the musical background. . . .

Edwin C. Hill will broadcast five times weekly for Barbasol now that Singin' Sam has left that program; vaudeville audiences will have a chance to view the deep-throated baritone singer during the next few months, for Harry Frankel—which is the right name of Singin' Sam—will make an extended tour, probably to the Coast and back; it is quite likely that Harry will have a chance in the talkies, for he is a fine-looking, tall handsome chap, and can act as well. We wish him luck. . . . Of course the Lombardo-Burns-Allen fans will be glad to know that this famous aggregation has won a long-term contract renewal from their sponsors, White Owl cigars; the program will be heard at the same time, Wednesdays, 9:30 p. m. . . . Jack Denny's Orchestra will be heard on the American Revue program starring Ethel Waters, for seven weeks, as a result of his guest appearance on November 26th. Jack is a lucky fellow; he loses the Silver Dust program and gains the Amco Oil Series. . . . Joe Haymes, who hails from Marshfield, Mo., where his folks ran a general store and Joe was interested in the candy counter, opens at the La Casa in Philadelphia this week. . . . And Abe Lyman is the current maestro of the Hotel New Yorker.

## FIGURE IT OUT YOURSELF

And Hear Ye! All Eddie Duchin fans—Eddie was born on April Fool's Day; no foolin'. Now, what does that signify? . . . And they do say that Isham Jones refuses to employ any but college-bred musicians! . . . And how they do commute to and from the Madison Avenue Radio Citadel: Georgie Jessel, planes from Florida to New York and back each week; Jane Froman and Don Ross make the jump from and to wherever the new "Follies" happen to be playing; and, of course, Frank Crumit and Julia Sanderson continue to make their regular trips from Springfield, Mass. . . . Have you heard the Greenwich Village Nut Club via Station WHOM? It's a scream. Every night at 10:45. . . . Another spot to be heard from over WHOM is the Coconut Grove in Newark, N. J., which features Phil Lynch and his orchestra. . . . Bob Pierce, the original "Old Man Sunshine," is on the air once more over WMCA. He and his famous dog "Bozo" may now be heard daily except Sundays at 5:45 p. m. . . . and Tom Noonan, the Bishop of Chinatown, is doing his little stunts over WMCA also, bringing good cheer to thousands of down-and-outers, and helping along the good work of the Free Employment Bureau of New York. . . . Another veteran radio artist on WMCA programs is Mildred Hunt, remembered by countless radio fans as Radio's Sweetheart; this little lady may now be heard with Nat Brusiloff's Orchestra every Sunday afternoon at 1:00 p. m. . . . Other programs worth the twist of the dial to WMCA are: the Biblical Drama series, Sundays at 8:30 p. m.; the Girl O' Yesterday, Kay Parsons, Mondays, Wednesdays and Fridays at 9:15 a. m. and Sally's Studio Party, with Al Shayne, every day at 5:00 p. m.

## RICHARD MACK ON DECK

Irving Mills announces the addition of Richard Mack to his staff at the Mills Art-

## A THOUGHT FOR THE WEEK

**F**RED ALLEN is a good comedian. He gets a big salary for his stage and radio work. He deserves it, for folks like him very much and his name is worth a lot to a sponsor. BUT—how about that gigolo story of his the other night! Pretty raw, we'd say! Could the advertising agency or the sponsor or the station director possibly have read that part of the program and permitted the lines to go through? Evidently—for there they were that all might hear. Can you imagine father's embarrassment when little Mary asked: "Daddy, what's a er-jig-er-jiggerlo?"

ists Bureau, Inc.; in his former connections Richard Mack did considerable authoring, script revising and production work in the radio department of the William Morris office; he was head continuity editor of the Cameo Broadcasting and Recording Company and also dialogued several films, including the Balinese "Isle of Paradise." Mack also has written special material for Fannie Brice, Red Grange, Lillian Morton, Mae Usher and a host of other stage and radio celebrities. . . . Guy Rennie scored a hit at the Petit Palais in New York upon his return from Europe; he has a novel way of presenting charming songs in a continental manner which is utterly delightful. . . . And to me the most delightful thing at this moment is a large portion of roast duck with sage and onion stuffing—and I didn't buy the duck from Joe Penner, either; so here goes; wish you might join me—and that goes for my friends in Cincinnati and Portsmouth, too. . . .

## From the LoudSpeaker

A study of one day's output by 206 commercial radio broadcasting stations, including program contents and sales talk interruptions to the listeners' entertainment, shows that popular music and jazz fill two-thirds of all program time.

Surveys which have been made of hundreds of thousands of radio owners through canvasses have revealed that adult listeners prefer first, news and information; second, classical music; third, popular music; fourth, dramatic presentations.

It would seem that wise radio station proprietors would give their listeners what they want. But they cannot. They must be led by the nose by those who "sponsor" the programs, namely the commercial advertisers.

Yet it is estimated that the power, new tubes, repairs and replacements on receiving sets cost annually \$300,000,000. Against this we have a maximum annual expenditure for all broadcasting by the stations of not more than \$80,000,000.

That means that the listeners are spending about four times as much on reception, to get what the advertiser thinks will sell his goods, as the stations are paying to give that "entertainment" to the listeners.

The time is fast approaching when the bureau in Washington responsible for this chaotic, unfair system of favoritism must listen to the voice of the people, whether it comes through a loudspeaker or through the ballot box.—*The Standard-Star*, New Rochelle, N. Y.

## Sales Talks

It is true that the sponsors of radio programs pay for our entertainment and for that reason should be permitted to tell about their products. But do they realize that instead of gaining good will they may only create ill will toward themselves and their products? Many times a radio listener will turn the receiver to another program just to avoid the sales talk on certain periods when otherwise the entertainment is high class.

# N. Y. C. STATIONS LEAN TO NEWS; PACT IN SIGHT

By ROBERT EICHBERG

Everyone is familiar with news broadcasts, and while it is unlikely that these have cut appreciably into the circulation of any newspaper, they do form the basis of a rapidly growing rivalry between the stations and the press. This rivalry is neither wise nor necessary.

Nevertheless, the rivalry is growing constantly. It is founded on the idea that radio stations are intended to serve the "public convenience and necessity"—and that people are interested in news. What it loses sight of is that the public is being well served with news by the daily papers, and that unless the stations are prepared to install news-gathering and editorial staffs commensurate with those of the major newspapers and syndicates, they cannot compete.

The first steps in this direction of rivalry have definitely been taken by the Columbia Broadcasting System.

The NBC has not acted as decisively as has CBS, but it also broadcasts for its various sponsors brief bulletins, news comment and so forth.

## Case of Small Stations

Both of these chains, or at any rate some of the commentators who broadcast on them, are said to have their own sources of news.

But what are the smaller, local stations doing? Powerful as the networks are, a true picture of the situation can be had only when the smaller fry are considered as well.

A short local survey was made for RADIO WORLD. This is the result.

WMCA, largest of the independents, works a tie-up with one of the local papers, broadcasting stock reports and news flashes by direct wire from the publishing plant early every afternoon. Further details on stocks are broadcast in the late afternoon; occasional evening programs on this station have dramatized the news events.

WOR, the most powerful local independent, puts on regular programs of news and comment.

WHOM, the third full-time local station in the Metropolitan area, has a definite policy against the use of news by radio stations.

## Editorials Emitted

In fact, WHOM leans the other way and broadcasts advertisements of all local papers which list its programs, and utilizes more than 100 bill-boards to advertise "Read our programs in the following papers," and has a standing offer to all papers, making its facilities available to them without cost or obligation whenever they wish to do any promotional work on the air. It does, however, broadcast comment on newspaper editorials (not news, but editorials) twice weekly, the talks being given by the managing editor of a leading Jersey paper.

WBNX, formerly key of the late "Third Chain," has broadcasts of Washington and financial news, which their broadcaster obtains from his own sources.

## Most Turn to News

WBBC receives a news service from one of the leading Brooklyn papers, on which it bases its news broadcasts. WMBQ has a news broadcast, but neither WLTH nor WBBR puts such material on the air. Nor, for that matter, does WFAB.

WINS, on the other hand, is an outlet of the Hearst newspapers and broadcasts

# Forum

## "Writing Down" Advocated

Editor, RADIO WORLD:

THERE ARE, no doubt, many radio men to whom the technical manner of presenting radio problems is perfectly satisfactory and understandable, but on the other hand, among the majority the algebraic manner of presentation in so much of your text cannot possibly be of any meaning, since few of the 42,000 amateurs have had any training in algebra, nor for that matter, do many of us feel any great need for going into the subject as a study.

We are not, as a majority, versed in the deeper "innards" of the radio problem, such as your learned author, J. E. Anderson; so that this type of matter is "strictly Greek." Your building articles are mostly composed of a mere schematic diagram and a technical explanation that leaves much to be desired as to clarity to us, of the "half learned." The placement of parts, which the author of your schematics must have engineered (unless the diagram is only a brain child) is rarely mentioned, leaving it to the experimenter to re-waste the time necessary to locate best placement of parts. Just why this information is rarely given suggests no models were built.

The most successful radio magazines in the field have been those which have denuded their informative articles of all the technical terms possible, which have used plenty of diagrams and various photos of placement of parts and manner of construction, and while there have been some in your publication, which have been articles of this class, they are entirely too few and far between.

Personally, I have had much enjoyment out of building many short-wave circuits and several broadcast receivers, and I feel that as the great majority lies with the amateur, a catering to a more simple way of explaining the phenomena of radio, and a "writing down" to the ability of the majority to understand, should be conducive to greater circulation of your publication.

O. A. TRONSTAD,  
P. O. Box 661,  
Dickinson, N. D.

\* \* \*

## A Voice from Canada

Editor, RADIO WORLD:

I have been a reader of RADIO WORLD for a long time and I wish to express my approval of your splendid, up-to-date publication. I think, though, you should give a little more explanation of your circuits and constructional data.

JACK SPARROW, Jr.,  
Ashley Post Office,  
Saskatchewan, Can.

\* \* \*

## Says J. E. A. Knows His Stuff

Editor, RADIO WORLD:

Please accept my thanks for the authenticity of your technique. J. E. Anderson and the others certainly know their stuff. Short waves are just beginning to come into their own, and I trust you will devote ample space to this topic.

My first experience building a short-wave set from your magazine was a grand success.

BERTRAM REINITZ,  
18 East Twenty-first Street,  
Brooklyn, N. Y.

news quite extensively. Both spot news and comment are featured regularly.

WEVD, with a tie-up to a foreign-language paper, also broadcasts matter relative to current events.

WVOV, one of the more popular small stations, has news programs in the early morning.

## Working Basis Prophesied

Disregarding the networks, you will notice that the majority of the stations is broadcasting news. In some cases the source of this news is not disclosed. In some, the

# NEW NETWORK'S FORMATION IS 10-MONTH TASK

The name Broadcasting Stations Corporation has been temporarily selected by George F. McClelland for the chain he is starting. Mr. McClelland resigned as vice-president and general manager of the National Broadcasting Company to start the new enterprise.

Another name for the outfit is in mind, but there is some doubt as to its availability, although it is said that arrangements are being made to clear up this point.

## Has Money Behind Him

Mr. McClelland is in no hurry to get the chain functioning, as he is familiar with the vast amount of foundation and organization work that must be accomplished before a chain can get started with assurance that it will continue what it did start. Recently the experience of new-chain endeavors has been one of long promises but short life.

Mr. McClelland has responsible financial backing, the details of which are being kept secret for the present. However, there is no use for artists to interview him now for immediate engagement, as there will be nothing doing in the actual program line until September, practically ten months from now. This long-range planning has made some chain aspirants blink.

The Federal Broadcasting Company is laying the groundwork for a chain, although present endeavors in that line, with a few stations tied in, are admittedly experimental. The headquarters of the company are at WMCA, New York City. Alfred E. Smith, former Governor of New York State, is chairman of the board of directors of the company.

Some chain skirmishing, also experimental, is being done by WFAB, New York City, WDEL, Wilmington, Del., WPEN, Philadelphia, and WOL, Washington, D. C., on a program-exchange basis at present, although with the hopes of getting sponsored chain programs when the number of stations is increased and the service area is fully canvassed.

## Wynn's Outfit Quit

The Amalgamated Broadcasting System, of which Ed Wynn, the comedian, was president, and in which he sank considerable money—said to have been \$250,000—is completely out of the picture. Some of the stations that were used by this chain are in the medium-sized station group associated with WFAB, known as the General Broadcasting Company.

"The idea of starting chains is currently popular," said one radio executive, "but the idea of making them pay and endure, though popular, is decidedly esoteric."

news is obtained from the station's own sources. But, in others, the papers themselves supply the stations with news.

This, in the writer's opinion, indicates that there will sooner or later be a definite working basis between the press and radio. It is already foreshadowed by arrangements which one of the major syndicates is making to charge an added fee to papers permitting stations to use their news material.

This may cause some papers to withdraw their services from stations. On the other hand, it may mark the first real business understanding between the Fourth and Fifth Estates.

## First Two-Way Talk By Hams Across Ocean Achieved 10 Years Ago

Ten years ago last month the Atlantic ocean was spanned for the first time by two-way amateur radio communication. It was the dawn of international amateur radio and of the short-wave movement for the first amateur transatlantic communication occurred on the comparatively short wavelength of 110 meters. It was the first use of short waves for communication over such distances, the first practical fruits of the short-wave experimentation initiated by amateurs and continued until what is now the greatest region in radio was finally opened up to the world a year or two later.

Fred H. Schnell, traffic manager of the American Radio Relay League, at station 1MO in Hartford, contacted Leon Deloy at station 8AB in Nice, France. A short while later John L. Reinartz, 1QP, of Manchester, Conn., who had developed the transmitting circuit all three stations were using, accomplished the same history-making feat.

These contacts were the climax of two years of constant effort. In 1921 the American Radio Relay League and a British radio magazine ran the first transatlantic tests, in which 25 American amateurs transmitted while 250 British amateurs listened. No signals were heard. Late that year the League sent Paul F. Godley, then the crack receiving expert of this country, to Scotland to listen for American stations. The outcome is one of the classic accomplishments of amateur radio. He heard a total of 26 American stations, on schedule, the first amateur trans-ocean reception at a land station.

In the winter of 1922 the third A.R.R.L. transatlantic tests were held, with literally hundreds of American amateurs heard in Europe, but no two-way contacts resulting. Elaborate preparations were made in anticipation of the fourth tests, to be held in December of 1923. But they never occurred. Schnell and Deloy had beaten the fireworks by nearly a month.

There was nothing accidental in their achievement. During the summer of 1923 Deloy had come to this country for the express purpose of preparing himself to be-

come the first foreign amateur to work two-way with America. He returned to France with a special American receiver and a flock of transmitting parts. On November 25th he cabled that he was ready to test, on 110 meters. On schedule, right from the first dot, he was heard in this country.

Schnell took a day to get his transmitter operating, and on November 27th again listened for Deloy. The throaty gargle from far-away France came in on schedule. A long call, and then the invitation to transmit. Schnell replied—and the first trans-ocean amateur radio conversation of history was on. The Atlantic had been conquered.

Ten years later Deloy, still at Nice, cables Schnell, now in Chicago: "On tenth anniversary first transatlantic short wave communication I send hearty greetings to you and all League friends.—Deloy."

## Westinghouse Making Police Transmitters

The radio division of Westinghouse in Chicopee Falls, Mass., is developing radio transmitting equipment for police service. The sets have a nominal rating of 250 watts but are especially designed to give economical operation on powers as low as 50 watts.

Internally there are two vertical racks, each containing individual panels. Each panel is an individual unit of the transmitter and may be removed for inspection or replacement, if ever necessary, without disturbing adjacent panels. All wiring is on a single plane and the rear is exposed to full view by opening the rear shields. Circulating fans at the bottom are used to carry away heat generated in the tubes and transformers.

The circuit is of fixed frequency. The only adjustment necessary is that at installation provided through the use of a special wrench supplied with the equipment. It is arranged for preadjustment to any frequency in the police band 1500-3000 kc. Accurately regulated quartz crystals are used to maintain constant radio frequency.

The input power for 100 watt operation is only 1250 watts so that complete set may be plugged into an ordinary 110 volt service receptacle. Rotating power equipment is not used and all parts are contained in the single cabinet.

## LAPEL MICROPHONE

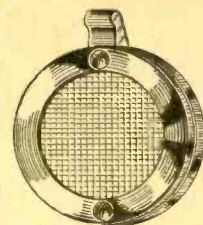

A single-button carbon-granule lapel microphone, impedance 200 ohms, requiring 4.5-volt excitation, of good frequency characteristics, and both handy and inconspicuous. Outside diameter, 1 5/8 inches. The case is chromium-plated brass. The excitation may be provided by introducing the microphone in a cathode circuit carrying around 20 to 25 milliamperes, or a 4.5-volt C biasing battery may be used. Net price, \$2.95.

**RELIABLE RADIO COMPANY**  
145 West 45th Street, New York, N. Y.

## Beginner's Twin S. W. Receiver with Hammarlund Parts

Acclaimed by RADIO WORLD readers, who have purchased a "TWIN," as the finest short wave set to learn the mysteries of short waves. A letter to N.Y. Sun, May 20th, from one of our customers, states that he received stations in England, Germany, Italy, Africa, Geneva and Spain.

Economical—Uses two 2-volt 230 low current tubes. **7.95**  
KIT OF PARTS (blueprints, 4 coils, etc.)  
Wired, with 4 coils (15-200 meters).....8.95

RELIABLE RADIO CO., 145 W. 45th St., N. Y. City

## COMPLETE TUBE CHARACTERISTICS WITH SOCKET CONNECTIONS

In Radio World dated Sept. 9, 1933. 15c a copy; or start your subscription with that issue. Radio World, 145 West 45th St., New York City.

## Quick-Action Classified Advertisements

7c a Word—\$1.00 Minimum

**NEW DEVELOPED CIRCUIT.** Five-tube super. Gets 3000 miles. Demonstration free. Barretto Radio, 13 Peck Slip, New York City.

**MODERN TUBE INDEX,** all tubes, all the dope, all manufacturers, socket connections, everything. Most complete of all. Sheet 21 x 27 inches. Price 25c. RADIO WORLD, 145 West 45th Street, New York, N. Y.

**"SPECIALIZED AUTO RADIO MANUAL,"** Vol. I, by John F. Rider—loose leaf—about 300 pages—up to the minute. Letter press printed. All diagrams clear and the figures easy to read. Covers old and new auto radio receivers, and includes recently announced auto radio installations. Price, \$3.50. RADIO WORLD, 145 West 45th Street, New York, N. Y.

**"RADIO AND TELEVISION,"** by James R. Cameron. Over 540 pages, 275 illustrations; cloth bound. The subject of radio and television covered in such a manner that it is easily understood even by a beginner. Price \$4.00. RADIO WORLD, 145 West 45th St., New York City.

**"MATHEMATICS FOR SELF STUDY,"** by J. E. Thompson, B.S. in E.E., A.M. A complete course in four inexpensive books: Arithmetic, Algebra, Trigonometry, Calculus, for the Practical Man. 1240 pages, cloth, illustrated, \$7.65. Radio World, 145 W. 45th St., New York City.

**THE FORD MODEL—"A" Car and Model "AA" Truck—Construction, Operation and Repair—Revised New Edition.** Ford Car authority. Victor W. Page. 708 pages, 318 illustrations. Price \$2.50. Radio World, 145 W. 45th St., New York.

**RADIO WORLD AND POPULAR MECHANICS MAGAZINE.**—Radio World is \$6.00 a year, and Popular Mechanics Magazine is \$2.50 a year. Popular Mechanics Magazine does not cut rates, but Radio World will send both publications to you for one year for \$7.00. Radio World, 145 West 45th St., New York City.

## The RADIO CONSTRUCTION LIBRARY

A MODERN SELF-TRAINING AND REFERENCE COURSE IN RADIO CONSTRUCTION AND SERVICING—

—including the construction of

SHORT-WAVE SETS and TELEVISION RECEIVERS

**T**HIS modern radio library, in addition to providing a thorough background of fundamental principles, covers fully the construction, operation and servicing of the latest type of receivers, including short-wave sets and television receivers.

The books serve alike the needs of the commercial radio dealer, set builder, radio installer and serviceman, as well as the amateur who keeps abreast of up-to-date broadcast reception by building his own set or changing the hookup.

### Complete Data on Modern Radio Construction and Repairing

The Radio Construction Library is both a home study course and a ready means of reference. It provides step-by-step information on every phase of radio set-building, trouble-shooting, installation and servicing.

It presents the latest data on sets, loudspeakers, and vacuum tubes, and contains complete information for the construction of short-wave and television receivers. With this set the serviceman is enabled to locate quickly all kinds of faults in installation, operation and reception. The books give the dealer a fund of knowledge upon which to draw in selling his sets, enable the amateur set builder to obtain the greatest benefit from his hobby and show the professional how to make his work more profitable.

3 volumes, 6 x 9, 1087 pages, 605 illustrations, \$7.50 complete—or any one book for \$2.50.

Book Dept., RADIO WORLD, 145 West 45th Street, New York City

### VOLUME I

#### PRACTICAL RADIO

378 pages, 5 1/2 x 8, 223 illustrations

This is a "foundation" book. It presents those principles involved in radio broadcasting and receiving which both the amateur and technically-trained expert must know in order to achieve results.

The book includes a trouble chart which gives at a glance the probable cause of most radio troubles.

### VOLUME II

#### RADIO CONSTRUCTION AND REPAIRING

386 pages, 5 1/2 x 8, 179 illustrations

This volume discusses the building of modern radio sets, including superheterodynes and short-wave receivers. It also covers the construction of loud speakers, eliminators and chargers, and includes complete information—diagrams, list of parts, detailed specifications, etc., for the construction and operation of a television receiver.

Detailed information is also given on testing and repairing radio receiving sets.

### VOLUME III

#### RADIO RECEIVING TUBES

323 pages, 5 1/2 x 8, 203 illustrations

This volume discusses in complete and clear detail the various functions of the radio vacuum tube, including the new types that have come into general use. The text covers the construction, action, reactivation and testing of tubes and also shows how they are employed in remote control, industrial processes and precision measurements.

Practical illustrations show how the vacuum tube is employed in prospecting, distant control of airplanes, automatic packaging machinery, surgery, and time switches.

**SPECIAL  
GIFT  
ISSUE**

# Reliable Radio Tips

Watch for  
This Special  
Page Weekly

## RELIABLE RADIO RUNS GIANT HOLIDAY SALE!!

FOR A PRACTICAL GIFT SUGGESTS GIVING A  
RADIO—LET THE ENTIRE FAMILY ENJOY IT

### Reliable Treasure Chest Receiver



A Handsome Four-Tube "Treasure Chest" model receiver which is a splendid piece of furniture and a high quality midget receiver. The beautifully designed cabinet built by craftsmen will satisfy the most critical person. Tubes used: 1-57, 1-58, 1-80 and 1-47 power pentode. Uses a full sized dynamic speaker. Price **\$9.50**  
4 tubes .....\$1.45

### Reliable 4 and 5 Tube A.C. Midgets

A practical gift for the entire family. The most advanced features are embodied in these receivers. Quiet, smooth, distortionless reception.

Four-tube receiver uses 1-57, 1-58, 1-80, and 1-47 pentode; five-tube set uses 1-57, 1-58, 1-80, and 2-47's. Both models use a dynamic speaker especially designed for the output of the pentodes. The receivers are encased in a beautiful hand-rubbed walnut cabinet. Price, 4-tube A. C. **\$9.95**

4 tubes .....\$1.45  
Price, 5-tube A. C. receiver.....\$12.95  
5 tubes .....\$1.95

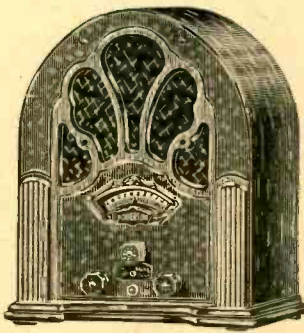

### Four Tube A.C. Short Wave Receiver

COMES MOUNTED INTO A BEAUTIFUL MODERNISTIC CABINET WITH BUILT-IN SPEAKER

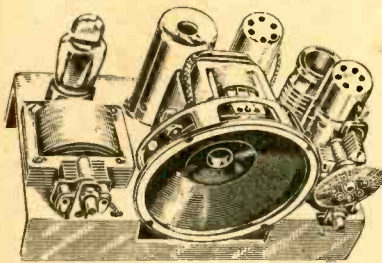

Looks like a midget broadcast receiver. Will tune in short wave stations from all parts of the world with ease. Uses four coils to cover the short wave bands from 15 to 200 meters. The built-in power supply is entirely free from hum or disturbing line noises. Uses an ultra-sensitive dynamic speaker to aid in tuning in the weaker signals. Kit of parts.....**\$17.50**

Wired and tested.....\$2.00 extra  
Kit of tubes.....\$1.95

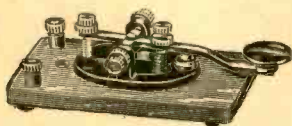

### Powertone Sending Key

The most practical gift to one who has just become interested in amateur radio. Widely used as a code practice key. Well balanced and fully adjustable. Price **75c**

### Stromberg-Carlson Phonograph Pickup

Makes any radio a modern up-to-date phonograph radio combination. Instruction sheet furnished with the outfit makes it simple to install. Volume control mounted on the pickup enables one to control the volume, without adjusting any part of your receiver. Special Holiday price **\$5.50**



### A Handy Manual Published for SERVICEMEN AND SET DEALERS

Full of information, hookups, charts, trouble shooting hints, etc. Reg. \$1.00 **25c**

### For The Beginners Rocket Two-Tube Short- Wave Battery Receiver

Economical! Uses two 2-230 tubes, which assures long battery life. Tunes from 15-200 meters. Pulls in amateurs, police calls, etc. Kit of parts.

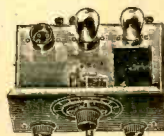

**\$5.50**

Wired..\$2.00 extra Tubes.....\$1.50  
Batteries .....\$2.25

### Powertone Two-Tube Bat- tery Receiver

Enclosed in a handsome crystal finished metal cabinet. Can be built by any one. Beautiful full vision modernistic vernier dial aids in logging weaker stations. Will receive all types of short-wave signals, police, amateur, ship-to-shore, airplane, etc.



Kit of parts..... **\$7.95**

Wired..\$2.00 extra Tubes.....\$1.95  
Batteries .....\$2.75

### A Power Pack That Converts Any Battery Operated Receiver Into an A.C. Receiver

Will convert any battery receiver to operate on a 110 volt A.C. line. All voltages terminate at binding posts on the chassis.



Output; 2 1/2 volts at 10 amperes, 180 volts tapped at 135, 90, and 45. Supplies clear hum-free power regardless of circuit sensitivity. Price including 280 rectifier tube. **\$5.95**

### GIFTS FOR THE SERVICEMAN

Majestic 70 and 90 Condenser Blocks



Replacement condenser blocks for the Majestic 70 and 90 series receivers. Built to the exact specifications of the original. Absolutely guaranteed. Price .....\$1.35

4 and 8 mfd. Electrolytic Condensers

High quality electrolytic condensers. Can be used as a replacement in many receivers without fear of breakdown. Wet type—thus cannot be injured by slight overload or polarity. Inverted mounting.

4 mfd ..... 35c  
8 mfd ..... 40c

RESISTORS

Assortment of 50



An assortment of 50 R.M.A. color coded resistors. Composed of 1/3, 1/2 and 1 watt resistors. All popular sizes are included in the kit ranging from 100 ohms to 10 megohms. **FREE** A beautiful bakelite case—a souvenir of the Chicago Century of Progress Exposition. Price .....\$2.50

### Farrand Inductor Dynamic Speaker Chassis

Not to be confused with the various models now on the market and labeled Farrand Inductors. These models are genuine factory-built Inductors.

Two models are available, a 12" model and a 9" model. Mounting brackets are placed on both models. Price, 9" model.....\$3.95 Price, 12" model.....\$5.95



### EXTRA! SHORT-WAVE SETS

ACCLAIMED THE IDEAL GIFT FOR RADIO-MINDED FOLKS

If you really want to please your radio-minded son, father, mother, brother, sister or friend this Christmas, give a short wave receiver. On this page are several very fine receivers for both the beginner and the more advanced short wave enthusiast, yet all at extremely low prices.



For A.C. and D.C. Operation

Will work anywhere that 110 volt A.C. or D.C. is available. U. S. amateur reception is assured on loud-speaker by the use of a 43 power tube in the output.



With headphones the entire world is at your finger-tips. Chassis is completely encased in a beautiful crystal finished cabinet. Covers the short wave, band form 15-200 meters. Uses 1-78, 1-25Z5, and 1-43 tube.

Price kit ..... **\$8.95**

Wired..\$2.00 extra Tubes.....\$3.25

### Beginners Twin Two-Tube Short-Wave Battery Receiver

A more advanced short-wave receiver for the beginner. Letters from builders verify foreign reception. Uses highest quality parts throughout.

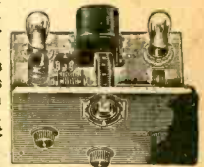

Complete with four plug-in coils to cover the entire short-wave band from 15 to 200 meters. Easy to build.

Kit of parts..... **\$8.95**

Wired..\$2.00 extra Tubes.....\$1.50  
Batteries .....\$2.50



# RADIO

REG. U.S. PAT. OFF.

# WORLD

DEC.  
23  
1933

15c  
Per Copy

The First and Only National Radio Weekly

613th Consecutive Issue—Twelfth Year

# SHORT WAVE SETS AND CONVERTER



# RADIO BUDAPEST!



## Radio Budapest

A rare announcement, even for the most hardened short-wave fan to hear, yet Capt. Hall, with his stock model POSTAL INTERNATIONAL, received Budapest on the loud speaker with an RT signal. You, too, can step out with a new POSTAL INTERNATIONAL Short-Wave 9-Tube Superheterodyne. Featuring a Tuned R. F. Pre-Selector Stage, 180 degree band spread on the 25 and 49 meter band, etc. Money back guarantee. Be sure to see and hear the POSTAL INTERNATIONAL. On demonstration from 9 A.M. to 12 Noon. Open until 7:30 P.M., or send 3-cent stamp for FREE DIAGRAM and circular describing the INTERNATIONAL.

## POSTAL RADIO CORP.

135 W. LIBERTY ST., NEW YORK  
Rector 2-0328 Room 305

**BOTH FOR ONE FULL YEAR  
RADIO WORLD  
and "RADIO NEWS"**

**\$7.00**

Canadian and Foreign, \$1.50 extra.

You can obtain the two leading radio technical magazines that cater to experimenters, service men and students, the first national radio weekly and the leading monthly for one year each, at a saving of \$1.50. The regular mail subscription rate for Radio World for one year, a new and fascinating copy each week for 52 weeks, is \$6.00. Send in \$1.00 extra, get "Radio News" also for a year—a new issue each month for twelve months. Total 64 issues for \$7.00.  
RADIO WORLD, 145 West 45th Street, New York, N. Y.

**MODERN TUBE INDEX**, all tubes, all the dope, all manufacturers, socket connections, everything. Most complete of all. Sheet 21 x 27 inches. Price 25c. RADIO WORLD, 145 West 45th Street, New York, N. Y.

## Vol. III of RIDER'S MANUAL (A New Book)

Just out, John F. Rider's Vol. III Manual weighs nearly 11 lbs. and has 1,100 pages, all diagrams of commercial receivers, etc. (no text). Sets announced up to May 1st, 1933, are included—and complete information on every one, including resistance values. The volume is original and necessary and does not repeat data that are in Vols. I and II.

A Chronological Catalog and Index of all nationally-advertised radio receivers manufactured and sold in the United States between January, 1921 and January, 1933 are contained in Volume III. This list will be of tremendous aid in the identification of receivers for which the model number is not known.

Complete data include schematic wiring diagrams; chassis wiring diagrams; parts layouts; photographic views of chassis; socket layouts; voltage data; resistor values; condenser values; location of alignment and trimmer condensers; alignment and trimmer adjustment frequencies; intermediate-frequency amplifier peaks; alignment and intermediate-frequency adjustment instructions; color coding; transformer connections; point-to-point data; continuity test data; parts list with prices; special notes.

Complete tabulation of tube data showing electrical characteristics and constants for all of the tubes employed in radio receivers and amplifiers since 1921. Also a table of interchangeable types.

A complete table of I-F. peak frequencies as used in radio receivers. This list augments the information of this type shown upon the diagram pages. Intermediate-frequency amplifier peak information is very important because quite a few of the manufacturers employ more than one figure in their year's production. A wrong guess on your part means trouble.

Order Cat. RM-3 @ \$7.50. Remit with order and we pay postage. Order C.O.D. and you pay postage.

Volume II—Order Cat. RM-3 @..... \$6.50



## METAL-WORKING

### LATHE

Precision equipment for the small shop. New designs and manufacturing processes make this amazing bargain possible. Complete metal-working lathe with compound slide-rest, combination face-plate and independent chuck and tail center; 6" swing; 24" length, 20 lbs. Send \$1.00, Balance plus postage C.O.D. Lathe for wood-turning alone, \$4. Attachments for milling, grinding, sanding, saw-table, etc., available at low prices. Order from ad at once and have a complete machine shop. American Machine & Tool Co., 200 Broadway, New York, Dept. R.8.

**\$7.50 COMPLETE**



## A Symbol

**THE** Yule log—symbol of Christmas through the ages. On the great holiday the lord of the manor threw wide the doors, and misery and squalor were forgotten in the cheer of the boar's head and was-sail.

Customs change, but the Christmas spirit is ageless. Today millions express it by the purchase of Christmas Seals—the penny stickers that fight tuberculosis—still the greatest public health problem. Your pennies will help.



**BUY CHRISTMAS SEALS**

## RCA INSTITUTES

Recognized Standard in Radio Instruction Since 1909  
**Technical Training Courses in Radio and Associated Electronic Arts**  
RESIDENT SCHOOLS NEW YORK AND CHICAGO  
Illustrated Catalog on Request  
EXTENSION COURSES FOR HOME STUDY under convenient "no obligation" plan.  
RCA INSTITUTES, INC.  
Dept. WR-1  
75 VARICK STREET, NEW YORK  
1154 MERCHANDISE MART, CHICAGO

## SPECIAL SMALL POWER TRANSFORMER

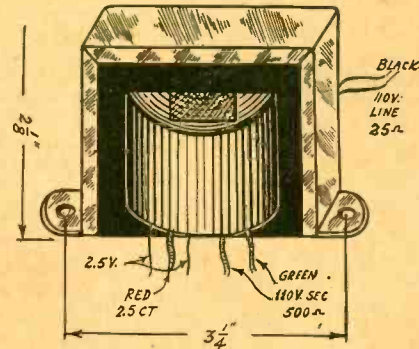

Filament-plate transformer, for oscillators, 1 or 2-tube sets, etc.  
Primary, 110 volts a-c.  
Secondary A, 2.5 volts, center-tapped; stands up to 3 amperes.  
Secondary B, 110 volts, not center-tapped.  
Excellent for test oscillators with a-c in plate.

Price, \$1.10  
**RADIO WORLD**  
145 West 45th Street New York, N. Y.

## Quick-Action Classified Advertisements

7¢ a Word—\$1.00 Minimum

**AIR CORPS TRAINS 600 MEN** yearly free; flying, radio, mechanics. Information for appointment, 25c. Lieut. Carroll, Box 533R, Taunton, Mass.

**"MODERN STORAGE BATTERY PRACTICE,"** by A. D. Althouse and Carl H. Turnquist, of Cass Technical High School, Detroit. A new and practical handbook prepared for the beginner and experienced battery man alike, and includes methods, materials, equipment, tables and special data, also index for quick references. 277 pages, 258 illustrations, flexible binding. Price \$2.50. RADIO WORLD, 145 W. 45th St., New York City.

**"WILLCOX AUTO ELECTRICIAN'S WIRING MANUAL"**—Complete wiring diagrams for all U. S. cars made in 1928-1929-1930-1931-1932. Complete data on ignition systems, generators, starting motors, batteries and lighting. Printed on tough, wear-resisting paper that can be washed with gasoline without injury to print or paper. Loose-leaf style in sturdy covers. Size 11 x 12". 300 wiring diagrams. Price \$10.00. RADIO WORLD, 145 W. 45th St., New York City.

**"AUTOMOBILE REFINISHING,"** by C. E. Packer, Member of S.A.E. For the car owner and professional refinisher. A practical handbook on the materials, methods and equipment used. 148 pages, 41 illustrations. Price \$1.50. RADIO WORLD, 145 W. 45th St., New York City.

**"SPECIALIZED AUTO RADIO MANUAL,"** Vol. I, by John F. Rider—loose leaf—about 300 pages—up to the minute. Letter press printed. All diagrams clear and the figures easy to read. Covers old and new auto radio receivers, and includes recently announced auto radio installations. Price, \$3.50. RADIO WORLD, 145 West 45th Street, New York, N. Y.

**"RADIO AND TELEVISION,"** by James R. Cameron. Over 540 pages, 275 illustrations; cloth bound. The subject of radio and television covered in such a manner that it is easily understood even by a beginner. Price \$4.00. RADIO WORLD, 145 West 45th St., New York City.

**"THE FORD V-EIGHT-'B'-FOUR-'BB'-TRUCK,"** by C. B. Manly. A New and Practical Book for Everyone Interested in the Construction, Adjustment, Upkeep and Repair of The New Fords. Over 250 pages, 125 illustrations. Complete cross index. Pocket size, flexible leatherette cover. Price \$2.00. Radio World, 145 W. 45th St., New York, N. Y.

## HENNESSY RADIO PUBLICATIONS CORP.

145 WEST 45th STREET, NEW YORK CITY

# Powertone Wallace Short Wave Receiver

The battery operated short-wave set which won the Hoover Cup for premier short-wave design and performance; well designed both electrically and mechanically. Built of the finest precision parts, each operating at maximum efficiency at all times; the Wallace has many features to recommend it to all interested in short-wave reception. Among these features are:

1. Band spread tuning for the crowded bands, controlled by a single panel switch.
2. Ultra Low-Loss coils wound with silver ribbon.
3. Each circuit individually controlled.
4. Highly efficient tuned antenna system.
5. Zero body capacity.
6. 15-200 meter tuning range.

The set is for earphone operation, using two 230 tubes, which require a 2-volt filament supply and 45-90 volts of "B" battery.

The receiver uses four plug-in coils whose tuning ranges are:

- |                          |                            |
|--------------------------|----------------------------|
| No. 1. coil—20-32 meters | No. 3. coil—75-150 meters  |
| No. 2. coil—40-60 meters | No. 4. coil—150-200 meters |

Complete kit of parts, with one coil ..... \$14.70  
Each additional coil..... 1.10  
Wiring and testing (if desired) extra..... 3.25

**Guaranty Radio Goods Co., 145 W. 45th St., New York, N. Y.**

**SPECIAL  
GIFT  
ISSUE**

# Reliable Radio Tips

Watch for  
This Special  
Page Weekly

## RELIABLE RADIO RUNS GIANT HOLIDAY SALE!!

FOR A PRACTICAL GIFT SUGGESTS GIVING A  
RADIO—LET THE ENTIRE FAMILY ENJOY IT

### Reliable Treasure Chest Receiver



A Handsome Four-Tube "Treasure Chest" model receiver which is a splendid piece of furniture and a high quality midget receiver. The beautifully designed cabinet built by craftsmen will satisfy the most critical person. Tubes used: 1-57, 1-58, 1-80 and 1-47 power pentode. Uses a full sized dynamic speaker. Price **\$9.50**  
4 tubes .....\$1.45

### Reliable 4 and 5 Tube A.C. Midgets

A practical gift for the entire family. The most advanced features are embodied in these receivers. Quiet, smooth, distortionless reception.

Four-tube receiver uses 1-57, 1-58, 1-80, and 1-47 pentode; five-tube set uses 1-57, 1-58, 1-80, and 2-47's. Both models use a dynamic speaker especially designed for the output of the pentodes. The receivers are encased in a beautiful hand-rubbed walnut cabinet. Price, 4-tube A. C. receiver ..... **\$9.95**

4 tubes .....\$1.45  
Price, 5-tube A. C. receiver.....\$12.95  
5 tubes .....\$1.95



### Four Tube A.C. Short Wave Receiver

COMES MOUNTED INTO A BEAUTIFUL MODERNISTIC CABINET WITH BUILT-IN SPEAKER

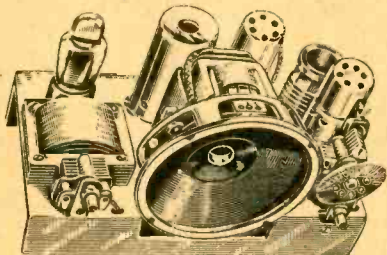

Looks like a midget broadcast receiver. Will tune in short wave stations from all parts of the world with ease. Uses four coils to cover the short wave bands from 15 to 200 meters. The built-in power supply is entirely free from hum or disturbing line noises. Uses an ultra-sensitive dynamic speaker to aid in tuning in the weaker signals. Kit of parts..... **\$17.50**

Wired and tested.....\$2.00 extra  
Kit of tubes.....\$1.95



### Powertone Sending Key

The most practical gift to one who has just become interested in amateur radio. Widely used as a code practice key. Well balanced and fully adjustable. Price.. **75c**

### Stromberg-Carlson Phonograph Pickup

Makes any radio a modern up-to-date phonograph radio combination. Instruction sheet furnished with the outfit makes it simple to install. Volume control mounted on the pickup enables one to control the volume, without adjusting any part of your receiver. Special Holiday price ..... **\$5.50**



### A Handy Manual Published for SERVICEMEN AND SET DEALERS

Full of information, hookups, charts, trouble shooting hints, etc. Reg. \$1.00 **25c**

### For The Beginners Rocket Two-Tube Short-Wave Battery Receiver

Economical! Uses two 2-230 tubes, which assures long battery life. Tunes from 15-200 meters. Pulls in amateurs, police calls, etc. Kit of parts.



**\$5.50**

Wired..\$2.00 extra Tubes.....\$1.50  
Batteries .....\$2.25

### Powertone Two-Tube Battery Receiver

Enclosed in a handsome crystal finished metal cabinet. Can be built by any one. Beautiful full vision modernistic vernier dial aids in logging weaker stations. Will receive all types of short-wave signals, police, amateur, ship-to-shore, airplane, etc. Kit of parts..... **\$7.95**



Wired..\$2.00 extra Tubes.....\$1.95  
Batteries .....\$2.75

### A Power Pack That Converts Any Battery Operated Receiver Into an A.C. Receiver

Will convert any battery receiver to operate on a 110 volt A.C. line. All voltages terminate at binding posts on the chassis. Output; 2 1/2 volts at 10 amperes, 180 volts tapped at 135, 90, and 45. Supplies clear hum-free power regardless of circuit sensitivity. Price including 280 rectifier tube. **\$5.95**

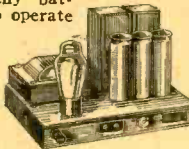

### EXTRA! SHORT-WAVE SETS

ACCLAIMED THE IDEAL GIFT FOR RADIO-MINDED FOLKS  
If you really want to please your radio-minded son, father, mother, brother, sister or friend this Christmas, give a short wave receiver. On this page are several very fine receivers for both the beginner and the more advanced short wave enthusiast, yet all at extremely low prices.

### POWERTONE SHORT WAVE WORLD RECEPTION A.C. D.C. RECEIVERS

For A.C. and D.C. Operation

Will work anywhere that 110 volt A.C. or D.C. is available. U. S. amateur reception is assured on loud-speaker by the use of a 43 power tube in the output.



With headphones the entire world is at your finger-tips. Chassis is completely encased in a beautiful crystal finished cabinet. Covers the short wave, band from 15-200 meters. Uses 1-78, 1-25Z5, and 1-43 tube. **\$8.95**  
Price kit .....\$8.95

Wired..\$2.00 extra Tubes.....\$3.25

### Beginners Twin Two-Tube Short-Wave Battery Receiver

A more advanced short-wave receiver for the beginner. Letters from builders verify foreign reception. Uses highest quality parts throughout. Complete with four plug-in coils to cover the entire short-wave band from 15 to 200 meters. Easy to build. **\$8.95**

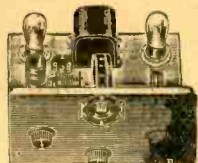

Kit of parts.....\$8.95  
Wired..\$2.00 extra Tubes.....\$1.50  
Batteries .....\$2.50

### GIFTS FOR THE SERVICEMAN

#### Majestic 70 and 90 Condenser Blocks



Replacement condenser blocks for the Majestic 70 and 90 series receivers. Built to the exact specifications of the original. Absolutely guaranteed. Price .....\$1.35

#### 4 and 8 mfd. Electrolytic Condensers

High quality electrolytic condensers. Can be used as a replacement in many receivers without fear of breakdown. Wet type—thus cannot be injured by slight overload or polarity. Inverted mounting.

4 mfd ..... 35c  
8 mfd. .... 40c

#### RESISTORS

Assortment of 50



An assortment of 50 R.M.A. color coded resistors. Composed of 1/3, 1/2 and 1 watt resistors. All popular sizes are included in the kit ranging from 100 ohms to 10 megohms.

FREE  
A beautiful bakelite case—a souvenir of the Chicago Century of Progress Exposition.

Price .....\$2.50

#### Farrand Inductor Dynamic Speaker Chassis

Not to be confused with the various models now on the market and labeled Farrand Inductors. These models are genuine factory-built Inductors.

Two models are available, a 12" model and a 9" model. Mounting brackets are placed on both models.

Price, 9" model.....\$3.95 Price, 12" model.....\$5.95



ROLAND BURKE HENNESSY  
Editor

HERMAN BERNARD  
Managing Editor

# RADIO WORLD

REG. U. S. PAT. OFF.

The First and Only National Radio Weekly  
TWELFTH YEAR

J. E. ANDERSON  
Technical Editor

J. MURRAY BARRON  
Advertising Manager

Vol. XXIV

DECEMBER 23d, 1933

No. 15. Whole No. 613

Published Weekly by Hennessy Radio Publications Corporation, 145 West 45th Street, New York, N. Y.

Editorial and Executive Offices: 145 West 45th Street, New York

Telephone: BR-gans 9-0558

OFFICERS: Roland Burke Hennessy, President and Treasurer; M. B. Hennessy, Vice-President; Herman Bernard, Secretary.

Entered as second-class matter March, 1922, at the Post Office at New York, N. Y., under Act of March 3, 1879. Title registered in U. S. Patent Office. Printed in the United States of America. We do not assume any responsibility for unsolicited manuscripts, photographs, drawings, etc., although we are careful with them.

Price, 15c per Copy; \$6.00 per Year by mail. \$1.00 extra per year in Foreign countries. Subscribers' change of address becomes effective two weeks after receipt of notice.

## SERIES CONDENSER

### In Antenna Circuit Improves Short-Wave Sensitivity Considerably

By Einar Andrews

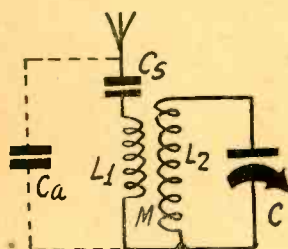

FIG. 1

A common method of coupling the antenna to the tuned circuit in a short-wave set, a small series condenser  $C_s$  being used to "shorten" the antenna.

THOSE who have played with short-wave receivers have found out that the performance of the circuits depends much on the value of the antenna series condenser. In Fig. 1 we have a typical arrangement of an antenna and tuned winding such as is used in short-wave receivers. The series condenser in question is  $C_s$ ,  $L_1$  is the inductance of the primary winding,  $L_2$  is the secondary inductance,  $C$  the tuning capacity,  $M$  is the mutual inductance between  $L_1$  and  $L_2$ , and  $C_a$  is the antenna capacity. This last factor is usually lost sight of because it is not strictly a circuit element. Nevertheless, it plays a very important part in the performance of the circuit. Resistances are not indicated, but there is a resistance in series with the antenna and another resistance in the coil  $L_2$ . Moreover, there is distributed inductance in the antenna, but this may be assumed to reside in the primary  $L_1$ . The mutual  $M$  is the mutual between the coils  $L_1$  and  $L_2$  only. We shall assume that the distributed inductance is small.

The signal voltage is in series with the

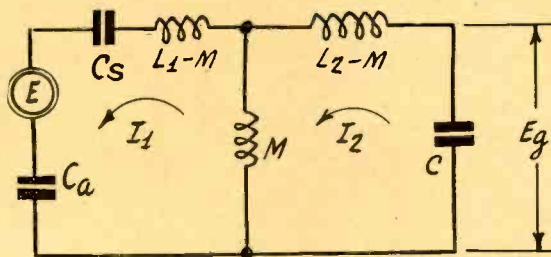

FIG. 2

This is the equivalent circuit of Fig. 1 showing how the mutual inductance couples and how the signal voltage is applied in series with the antenna capacity.

antenna condenser  $C_a$  and in the equivalent circuit in Fig. 2 it is indicated by  $E$ . The effectiveness of the arrangement is the ratio between  $E_g$ , the voltage across the tuning condenser, and  $E$ , the signal voltage picked up. If  $Z_m$  is the impedance of the mutual,  $Z_a$  the impedance of the antenna condenser,  $Z_s$  the impedance of the series condenser,  $Z_1$  the impedance of the primary, and  $Z_2$  that of the secondary, and  $Z_c$  that of the tuning condenser, the ratio  $E_g/E$  is given by the expression

$$A = \frac{Z_m Z_c}{[(Z_a + Z_s + Z_1)(Z_c + Z_2) - Z_m^2]}$$

If we neglect the resistances and express the impedances as reactances, this expression becomes

$$A = \frac{M}{[L_2 C / C_a + L_2 C / C_s + L_1 + (M^2 - L_1 L_2) w^2 C - (1/C_a + 1/C_s) / w^2]}$$

$A$  being regarded as amplification.  $A$  is greatest at the frequency that makes the quantity within the brackets least. This occurs when  $w$  has the value given by the expression

$$w^4 = [(1/C_a + 1/C_s) / (L_1 L_2 - M^2 C)]$$

Therefore the frequency of resonance depends on  $C_a$ ,  $C_s$ ,  $L_1$ , and  $M$  as well as on  $L_2$  and  $C$ . Therefore we can tune the circuit to some extent by varying the coupling  $M$  and the series capacity  $C_s$ , and that is a common experience. Indeed, the series condenser is often used for tuning.

Of especial interest is the value of the amplification when the circuit is tuned to maximum response, that is, when the terms containing the frequency cancel each other. This amplification is

$$A = M C_a C_s / [L_2 C (C_a + C_s) + L_1 C_a C_s]$$

Therefore the gain is directly proportional to the mutual inductance. It also increases as  $C_s$  increases. This also is common experience.

#### An Incomplete Tale

But the expressions given above do not tell the whole story because the resistances were neglected. If they are taken into account the frequency of maximum gain is slightly different, and the gain is vastly different. Only in degree, however. The main effect of the resistances is to decrease the selectivity. As the gain is increased as indicated above, that is, by increasing the mutual inductance and by increasing the capacity of the series condenser, the selectivity goes down. It is more important, as a rule, to have high selectivity than high gain. Therefore the main function of the series condenser is to increase the selectivity of the circuit, which is accomplished by reducing the value of  $C_s$ .

#### Another Arrangement

Another arrangement that is often used on short-wave sets is that shown in Fig. 3, the equivalent circuit of which is given in Fig. 4. In this case the maximum gain is obtained when

$$w^2 = (1/C_s + 1/C_a) / [L(1 + C/C_a + C_s)]$$

Therefore in this case also the tuning is

affected by the series condenser. The smaller  $C_s$  is the more nearly does the frequency of resonance coincide with the natural frequency of the LC circuit, and, incidentally, the greater is the selectivity.

When the circuit arrangement in Fig. 3 is used it is especially important that the series condenser be small because there is no mutual inductance that can be varied to obtain the same effect as that obtained with a small condenser.

**Distributed Inductance**

When the coupling between the antenna and the tuned secondary is close, whether the closeness is obtained by means of a large series condenser, or no condenser at all, or a large mutual inductance, the resistance in the antenna is transferred more or less into the tuned circuit, and the selectivity is decreased in proportion to the amount of resistance so transferred. It is possible to have an arrangement such that there is no selectivity at all in the tuned circuit. That occurs when the antenna circuit is in resonance with the frequency to which the secondary is supposed to be tuned. The antenna capacity, the series capacity, the antenna distributed inductance, and the primary inductance resonate with the frequency. In such cases the selectivity of the receiver can be improved by putting a high resistance in series with the antenna lead.

The distributed inductance of an antenna may be entirely negligible when the antenna is used for broadcast reception, yet it may be much larger than the lumped inductance of the primary when the circuit is used for short-wave reception. An outdoor antenna about 75 feet long may have an inductance of the order of 20 microhenries. Indeed, that is the inductance of the standard antenna, and they have not selected the maximum distributed inductance for the standard. The inductance of the primary of a short-wave coil may not be more than a few microhenries. Consequently the distributed inductance cannot always be neglected.

**Natural Frequency**

Every antenna has a certain natural frequency of resonance, which is determined by the self capacity and the distributed inductance. The capacity might be of the order of 300 mmfd., and therefore, if the inductance is 20 microhenries, the natural frequency of resonance would be about 2 million cycles per second. Thus it would resonate with that frequency and if the secondary were tuned to the same frequency there would be practically no selectivity, unless the coupling between the two tuned circuits were very loose.

If the frequency of resonance does fall in the tuning range of the secondary circuit, it can be changed by means of the series condenser and thus the difficulty of broad tuning is avoided. Suppose, for example, that in series with the antenna specified above a condenser of 50 mmfd. were connected. This would change the effective capacity in series with the circuit to 43.4 mmfd. and the natural frequency of resonance to 5.4 million cycles per second. That would make the antenna useful for frequencies up to about 5 million cycles per second. Of course, 50 mmfd. is not the lowest value that can be used if it is necessary to go lower.

**Use of Short Antenna**

Putting a small condenser in series with the antenna is called shortening the antenna because it has the same effect as actually making the antenna shorter, at least as far as the effective capacity is concerned. An actual shortening of the antenna would also reduce the distributed inductance, which the series condenser does not do.

Therefore when short waves are to be

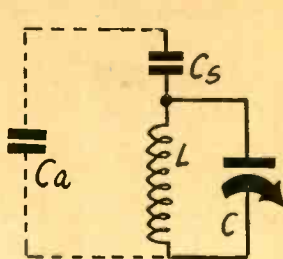

FIG. 3

This is also a common method of coupling the antenna to a short wave tuner. The series condenser is placed between the antenna and the tuned circuit.

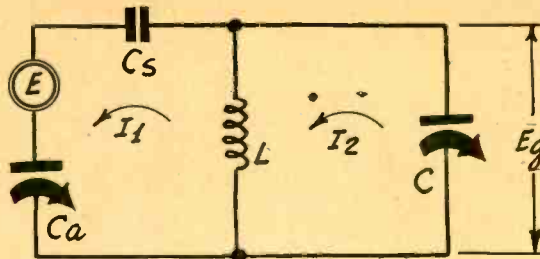

FIG. 4

The equivalent circuit of Fig. 3, showing how the signal voltage is applied in series with the antenna capacity and the series capacity, all in shunt with the tuned circuit.

received it is best to use a short antenna, one that has both low self capacity and distributed inductance. If a good short outdoor antenna cannot be erected it would be better to use an indoor antenna.

When regeneration is used in a short-wave receiver next to the antenna, it is found that the smaller the antenna series condenser the more easily does the circuit oscillate. This is just additional evidence that the antenna resistance is transferred into the tuner, for when there is high resistance in the tuner the circuit does not oscillate so readily as when there is very little resistance.

It is also found in many receivers that are not supposed to oscillate that they do so when the series condenser is reduced in size. The damping effect of the antenna resistance when the condenser is large is just sufficient to offset the feedback in the amplifier that causes the oscillation. This is still more evidence that the small condenser in the antenna "shuts out" resistance.

**A Direct Coupled Circuit**

Sometimes the antenna is connected to the tuned coil in the manner shown in Fig. 5. The equivalent circuit may then be represented as in Fig. 6. The effective inductance in the tuned circuit is  $L_1 + L_2 + 2M$ , that is, it is the total inductance of the coil across which the tuning condenser C is connected. The antenna circuit is then connected in series with the inductance M as indicated. If the distributed inductance in the circuit must be taken into account it is in series with  $C_a$ , and hence in series with M and  $C_s$ . The mutual inductance in this circuit is negative and, therefore, it partly nullifies the distributed inductance.

In this case, also, it is clear that the antenna capacity and the series capacity af-

fect the tuning. In order to reduce the effect of the antenna resistance on the tuned circuit and also the antenna reactance on the frequency, the value of M should be made low and also the value of  $L_1$ . That is, the antenna condenser should be connected to a tap on the coil that is very near ground. Besides this the series condenser  $C_s$  should be small, as in all other cases.

The only way to do anything about the value of the antenna capacity  $C_a$  is to make the antenna shorter, but that is hardly a practical method of operating a receiver. But, as was stated before, if the antenna capacity is small the series capacity is not needed, except as a means of varying the volume and the selectivity.

**Not Too Short, Please!**

While reducing the antenna height reduces the capacity  $C_a$  and also the distributed inductance, it also reduces the value of the signal picked up, that is, it reduces E. Hence it will not do to use a too short antenna, either. One of fifteen feet running straight up in the air is all right when the short-wave receiver is sensitive. This applies to any case, regardless of the particular method employed in getting the signal from the antenna to the tuned circuit.

Loop antennas are not used extensively on short-wave receivers because they are clumsy and inconvenient. But if they are to be used at any time, it should be when short waves are received, because their efficiency increases rapidly as the frequency of the signal increases. For the shorter of the short waves a loop about a foot on the side is quite effective, and the loop could be the first tuning inductance. Besides a high selectivity in the loop, it has the advantage of directional selectivity.

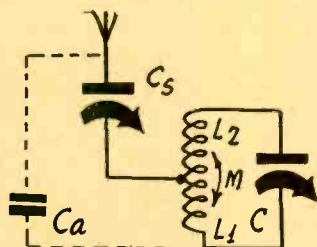

FIG. 5

Sometimes the series condenser is connected to a tap on the tuned coil as in this case. The lower the tap the looser the coupling and the smaller the series condenser the greater the selectivity.

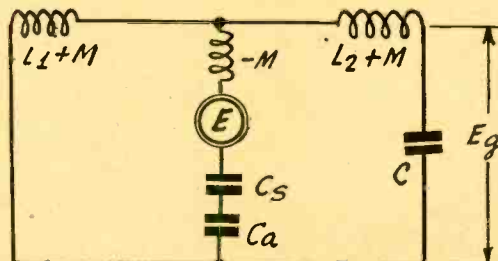

FIG. 6

This is the equivalent circuit of Fig. 5. As in all cases the antenna and series capacity affect the frequency of resonance, and the selectivity and the sensitivity of the receiver.

# DUAL CONTROL

## Of Regeneration for Easiest Access to Highest Sensitivity

By Calvin Edward Laight

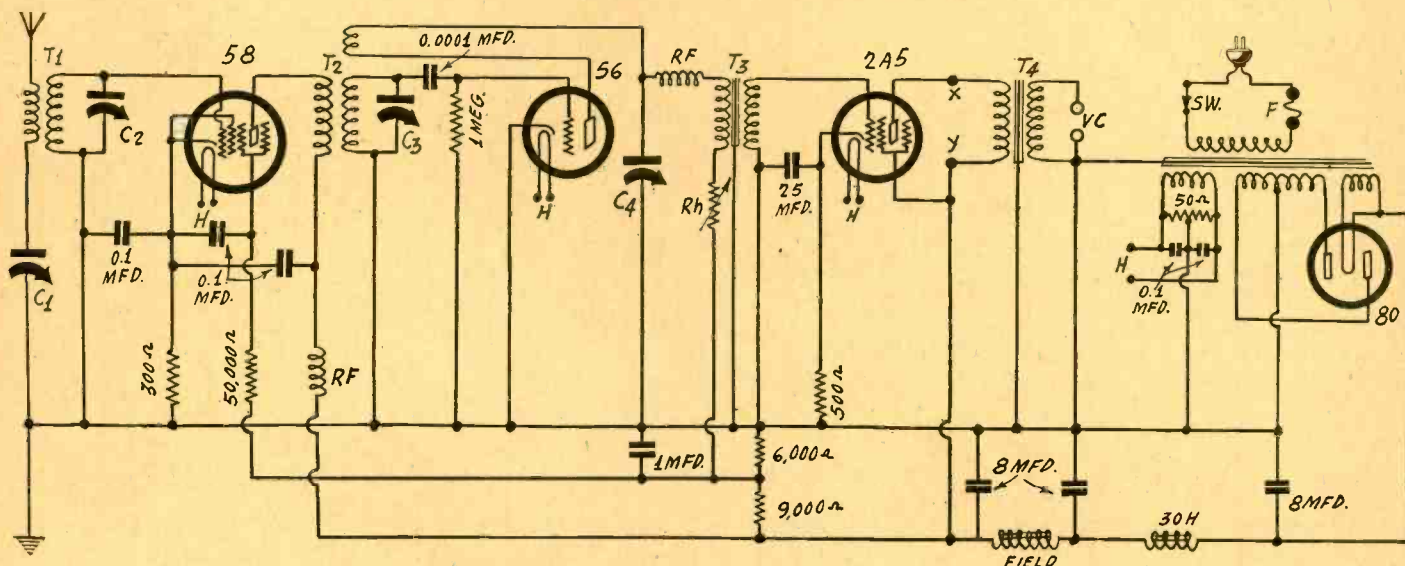

FIG. 1.

The circuit of a four-tube regenerative short-wave receiver employing a 58 radio frequency amplifier, a 56 detector, a 2A5 power amplifier, and an 80 rectifier.

HERE is a four-tube regenerative short-wave set utilizing a 58 as a tuned radio frequency amplifier, a 56 as a detector, and a 2A5 as a power amplifier. An 80 in a regular rectifier circuit is employed as the power supply.

When regeneration is employed in a short wave receiver the most critical part of the circuit is the feed back control. The performance of the receiver depends on the smoothness with which the regeneration can be controlled. There are two provisions in this circuit for varying the amount of feedback, one a 140 mmfd. condenser C4 and the other a rheostat Rh of 50,000 ohms. The variable condenser is used for fine control and the variable resistor for course control. The object of Rh is to vary the effective voltage on the detector plate and thus vary the oscillation and detection efficiencies of the tube.

It may be that for a given voltage on the plate the regeneration cannot be controlled smoothly with the variable condenser. The

effective voltage should then be decreased by increasing the resistance in Rh. The thing to avoid is sudden starts and stops of oscillation, for when the set is in that condition it is not possible to take advantage of all the regeneration.

### The Input Tuner

A radio frequency transformer T1 is employed between the antenna and the first tube, and this should preferably be of the plug-in type. A small variable condenser C1 of not more than 100 mmfd. is put in series with the antenna to adapt it to the short waves and also to act as a selectivity and volume control. The condenser is put on the ground side in order to permit grounding the rotor plates. Ordinarily this is not done, but it can be done without difficulty if there are four independent terminals on the plug-in coil.

The tuning condenser C2 placed across the secondary of the transformer should

have a capacity of 140 mmfd. This condenser may be ganged with the condenser C3 across the secondary of the regenerative coil, provided that the circuits are trimmed accurately. There would have to be one trimmer condenser built into each plug-in coil in order to have the circuits track regardless of which coil pair were plugged in. In case it is not desired to put so many trimmer condensers into the circuit the trimming will have to be done with a small condenser available from the panel and connected across the secondary of either T1 or T2. It should first be put across the C3 for it is most likely that the capacity in this circuit will be less than that in the first circuit.

If C2 and C3 are not ganged all trimmer condensers are unnecessary but then it is slightly more difficult to tune the circuit, for there will be two main controls to manipulate. Of course, if the coils are equal and the coupling in T1 is not too close, and

(Continued on next page)

### LIST OF PARTS

**Coils**  
 T1—One set of four-terminal radio frequency coils of plug-in type, for 140 mmfd. condenser  
 T2—One set of six-terminal radio frequency coils of the plug-in type, for 140 mmfd. condenser  
 RF—Two 10-millihenry radio frequency choke coils  
 One 30-henry audio-frequency choke  
 T3—One audio frequency transformer  
 T4—One loudspeaker for 2A5 tube with output transformer and field coil  
 T5—One power transformer having one 2.5-volt winding, one 5-volt winding and center-tapped high-voltage winding

**Condensers**  
 C1—One 100 mmfd. variable condenser with knob

C2, C3—Two 140 mmfd. variable condensers, ganged and provided with a vernier dial, or two condensers with two dials (If a two-section gang is used a trimmer condenser is required)  
 C4—One 140 mmfd. variable condenser with knob  
 Five 0.1 mfd. by-pass condensers  
 One 0.0001 mfd. grid condenser  
 One 1 mfd. by-pass condenser  
 One 25 mfd., 35-volt electrolytic by-pass condenser  
 Three 8 mfd. electrolytic filter condensers

### Resistors

One 300-ohm bias resistor  
 One 500-ohm bias resistor  
 One 50-ohm. centertapped resistor

One 50,000-ohm resistor  
 One one-megohm grid leak  
 One 50,000-ohm variable resistor with line switch attached and with knob  
 One 6,000-ohm, 3-watt resistor  
 One 9,000-ohm, 3-watt resistor

### Other Requirements

Antenna and ground binding posts  
 One four-contact socket  
 One five-contact socket  
 One medium six-contact socket  
 One small six-contact socket  
 One one-ampere fuse  
 One grid clip  
 One small four-tube chassis